

Hatch Covers

USS-HC32X32

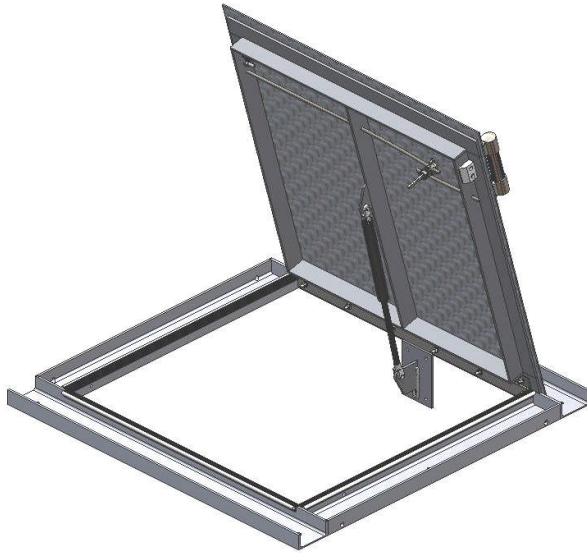

Specifications

Cover

- Sheared to size and pressed into shape using 3003 Aluminum Tread-Brite 0.125" thick.
- Gas Springs reduce lift weight to 20 - 40 lbs and dampen movement during closure.
- Grab Handle and T-Lock assemblies are Stainless Steel or Aluminum.
- Bolts and Fasteners are Stainless Steel.

Sub-Assembly

- Structural 6061 Aluminum.

Optional—Cover Seal

- Resistant to common airport chemicals.
- Reduces fluid entry due to blowing winds.
- Ozone/UV resistant with field life of one year.

Optional

- Safety Hold-Open Latch.

Hatch Applications

Fuel

- Isolation Valve Vault Access
- Oil/Water Separator Tank

Electrical

- 50/60/400 Hertz
- 28/72 Volt DC

Air

- Compressed
- Engine Start
- Preconditioned

Water

- Fire Protection
- Lavatory
- Potable and Wash
- Sump

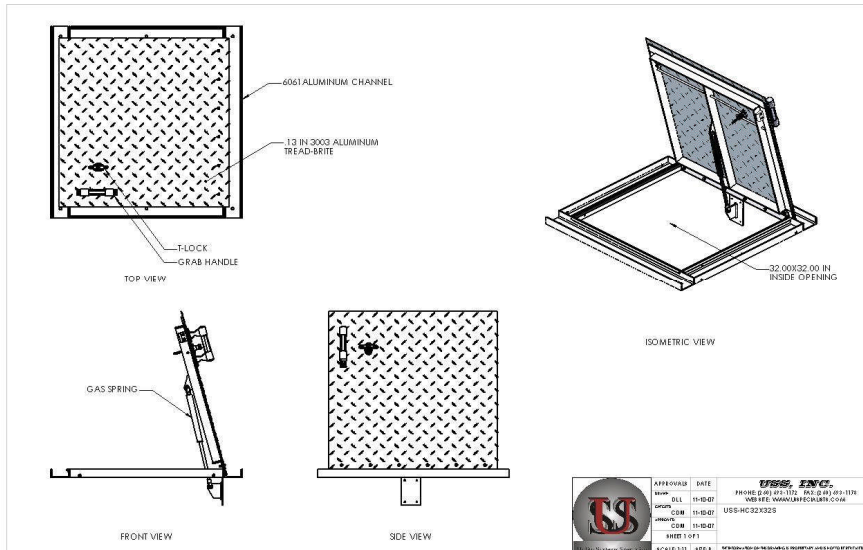

General Information

- USS, Inc. has assembled a team of manufacturers who have proven their ability to provide quality products delivered on schedule.
- Our fabrication shop was established in 1976; has grown to over forty-eight thousand square foot facility producing large floating barges, oil storage tanks; offering plasma, laser, and certified welding services
- USS, Inc. provides the highest quality products and service at a competitive price with minimal use of proprietary components.

USS, Inc.

9745 East State Road 205-57
Churubusco, IN 46723

Phone: (260) 693-1172
FAX: (260) 693-1178
E-Mail: carl@usspecialists.com
Website: www.usspecialists.com