

TOP VIEW

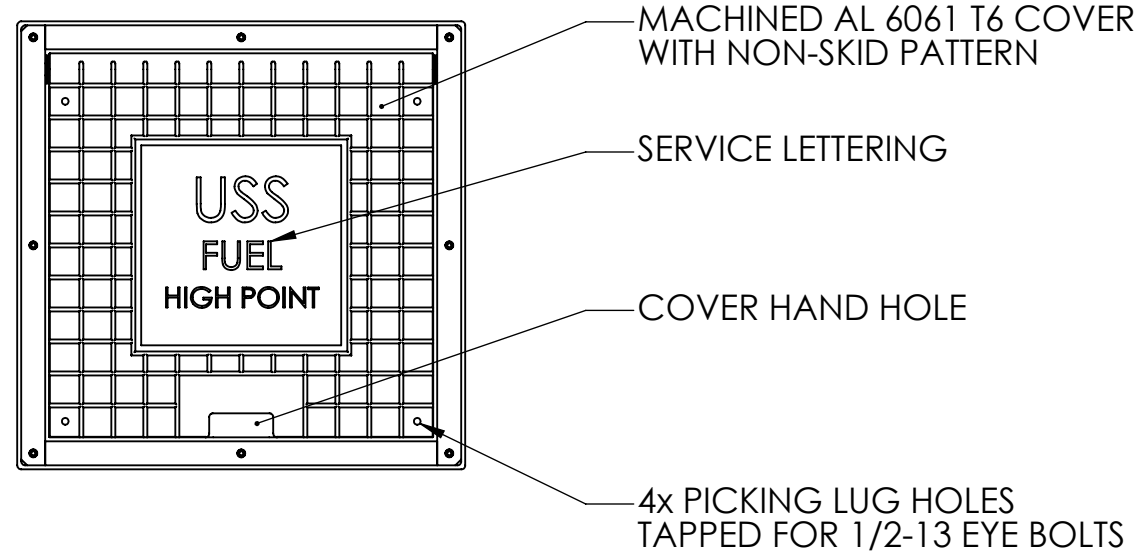

PLAN VIEW

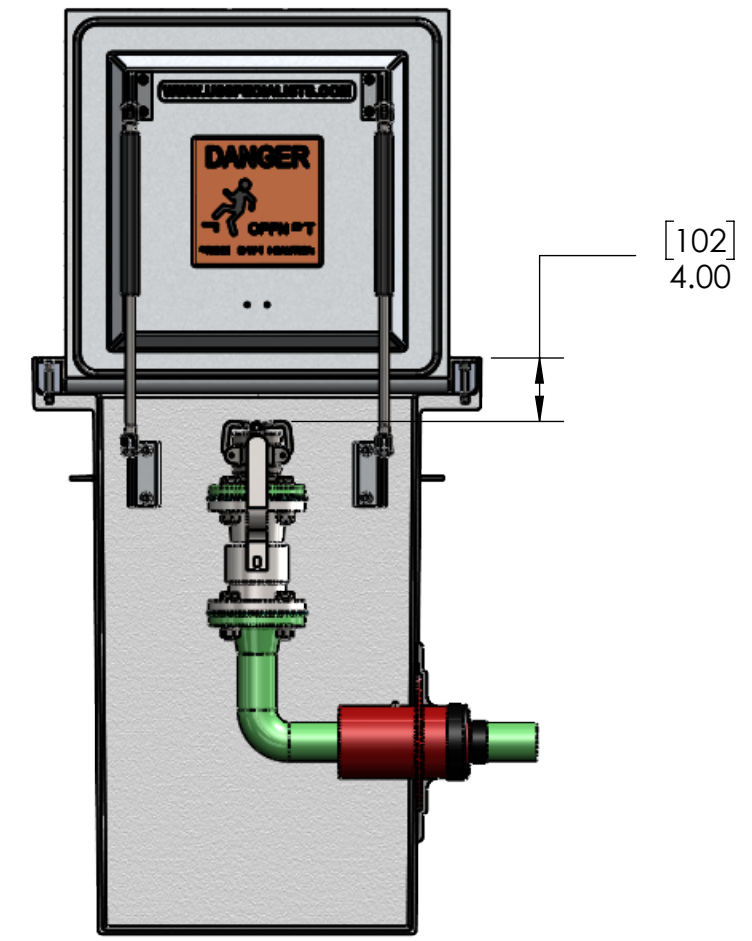

FRONT CUT VIEW

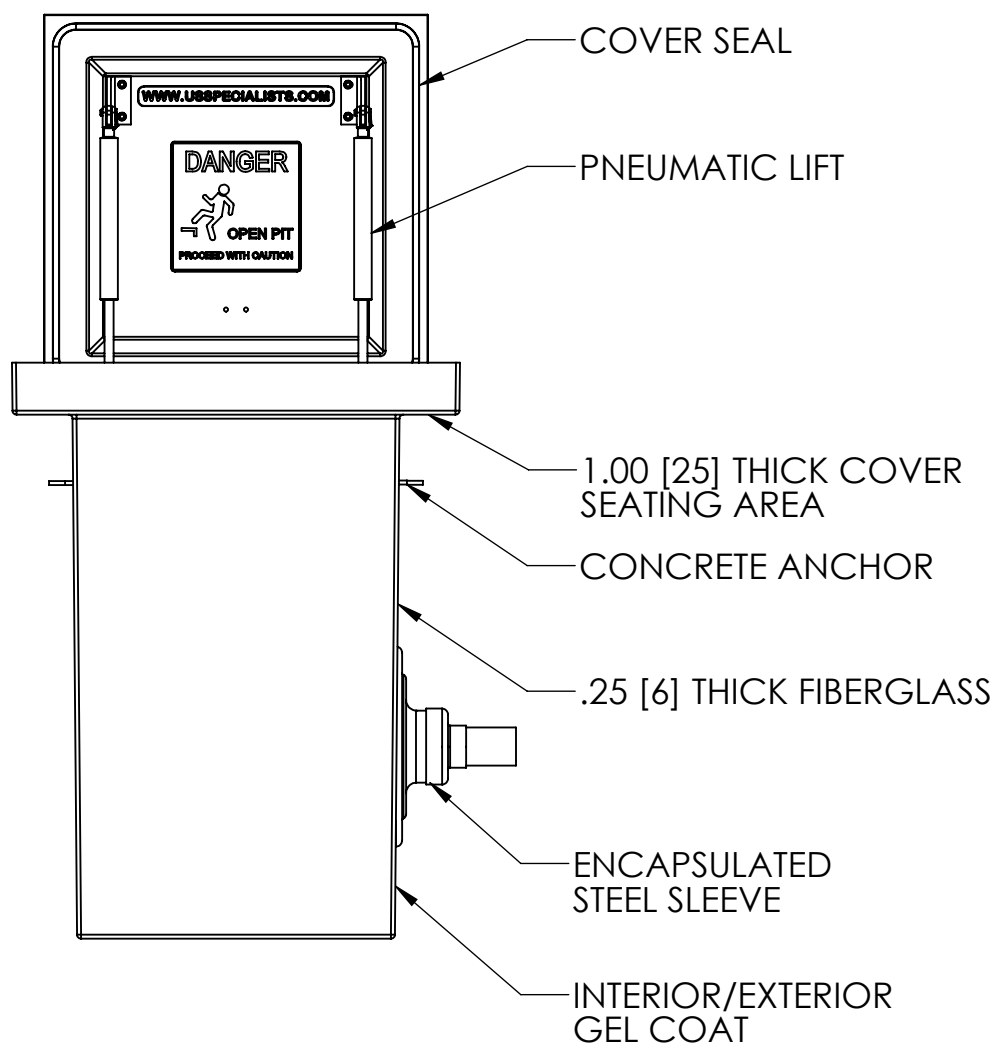

FRONT VIEW

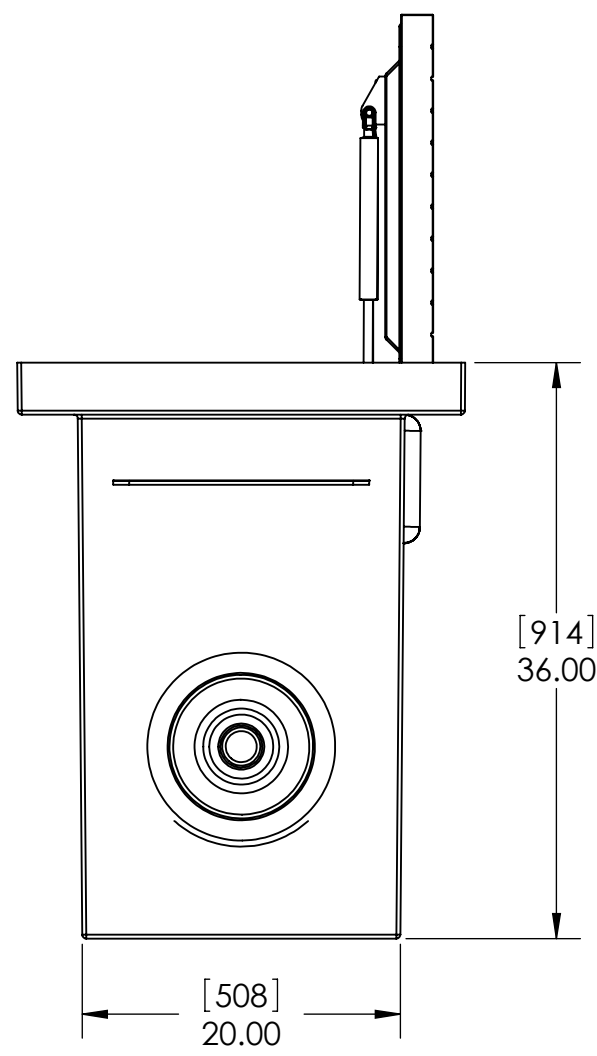

SIDE VIEW

[MILLIMETERS]  
INCHES

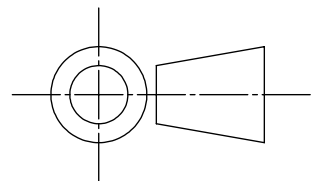

INTERNAL COMPONENTS SHOWN FOR REFERENCE.  
NO INTERNAL COMPONENTS PROVIDED



APPROVALS	DATE
DRAWN DLL	08-27-24
CHECKED DLL	08-27-24
APPROVED CDM	08-27-24
SHEET 1 OF 3	
SCALE: 1:12	SIZE: B

**USS, LLC**  
PHONE: (260) 693-1172 FAX: (260) 693-1178  
WEB SITE: WWW.USSPECIALISTS.COM

**USS24-20x20-36D**  
**HPVSA(2)[4]**  
**3 VIEW, PLAN, CUT**

THE INFORMATION ON THIS DRAWING IS PROPRIETARY AND IS NOT TO BE REVEALED TO THIRD PARTIES WITHOUT WRITTEN CONSENT OF A CORPORATE OFFICER OF USS, LLC.

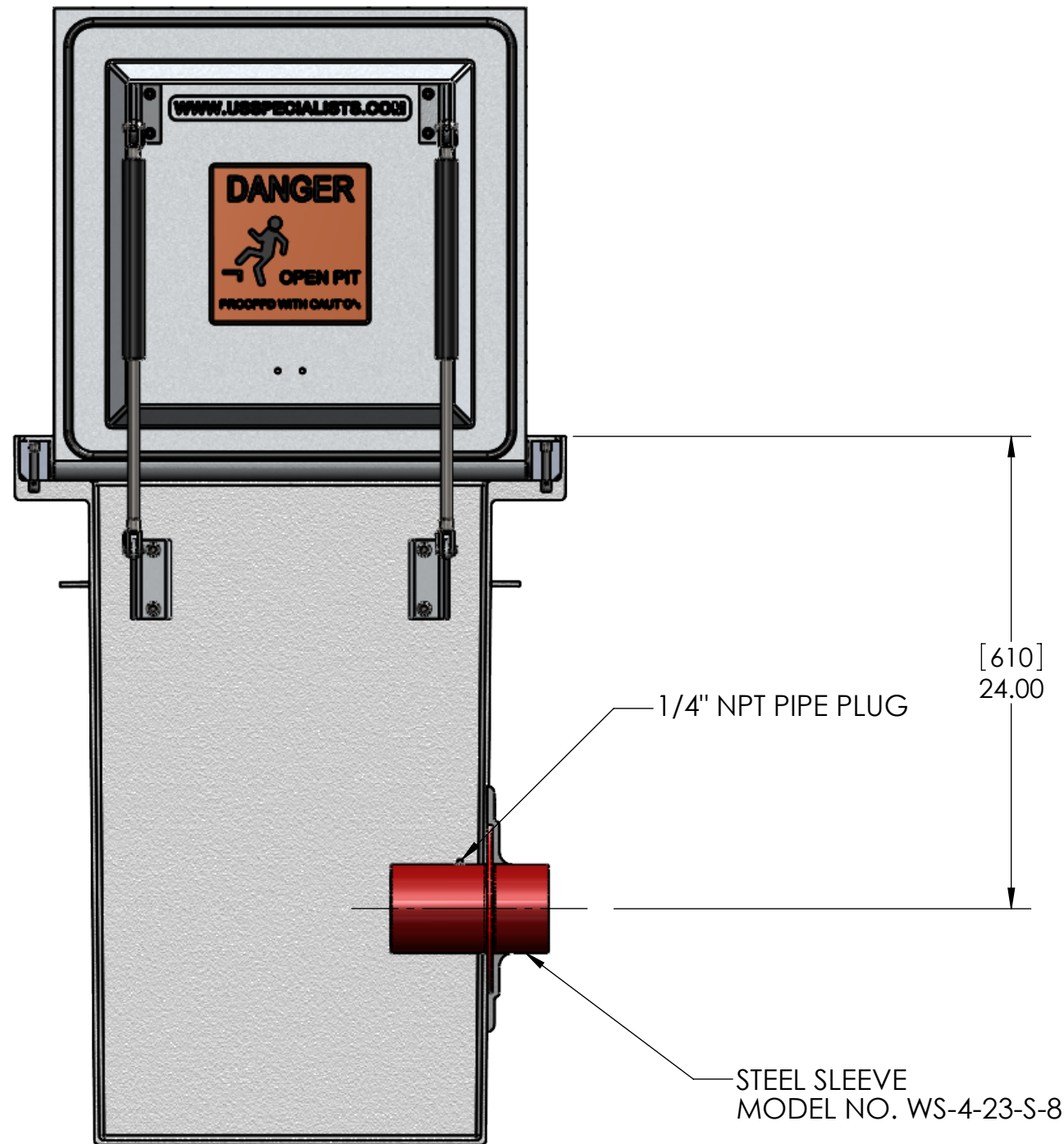

QUANTITY \_\_\_\_\_

**RELEASE FOR FABRICATION**

NAME _____	SIGNATURE _____
DATE _____	COMPANY _____

APPROVALS	DATE
DRAWN DLL	08-27-24
CHECKED DLL	08-27-24
APPROVED CDM	08-27-24
SHEET 2 OF 3	
SCALE: 1:8	SIZE: B

**USS, LLC**  
 PHONE: (260) 693-1172 FAX: (260) 693-1178  
 WEB SITE: WWW.USSPECIALISTS.COM

**USS24-20x20-36D**  
**HPVSA(2)[4]**  
**SUBMITTAL**

THE INFORMATION ON THIS DRAWING IS PROPRIETARY AND IS NOT TO BE REVEALED TO THIRD PARTIES WITHOUT WRITTEN CONSENT OF A CORPORATE OFFICER OF USS, LLC.

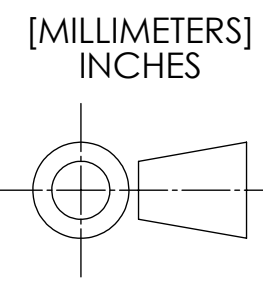

EMPTY PIT: 293 LB [133 KG]

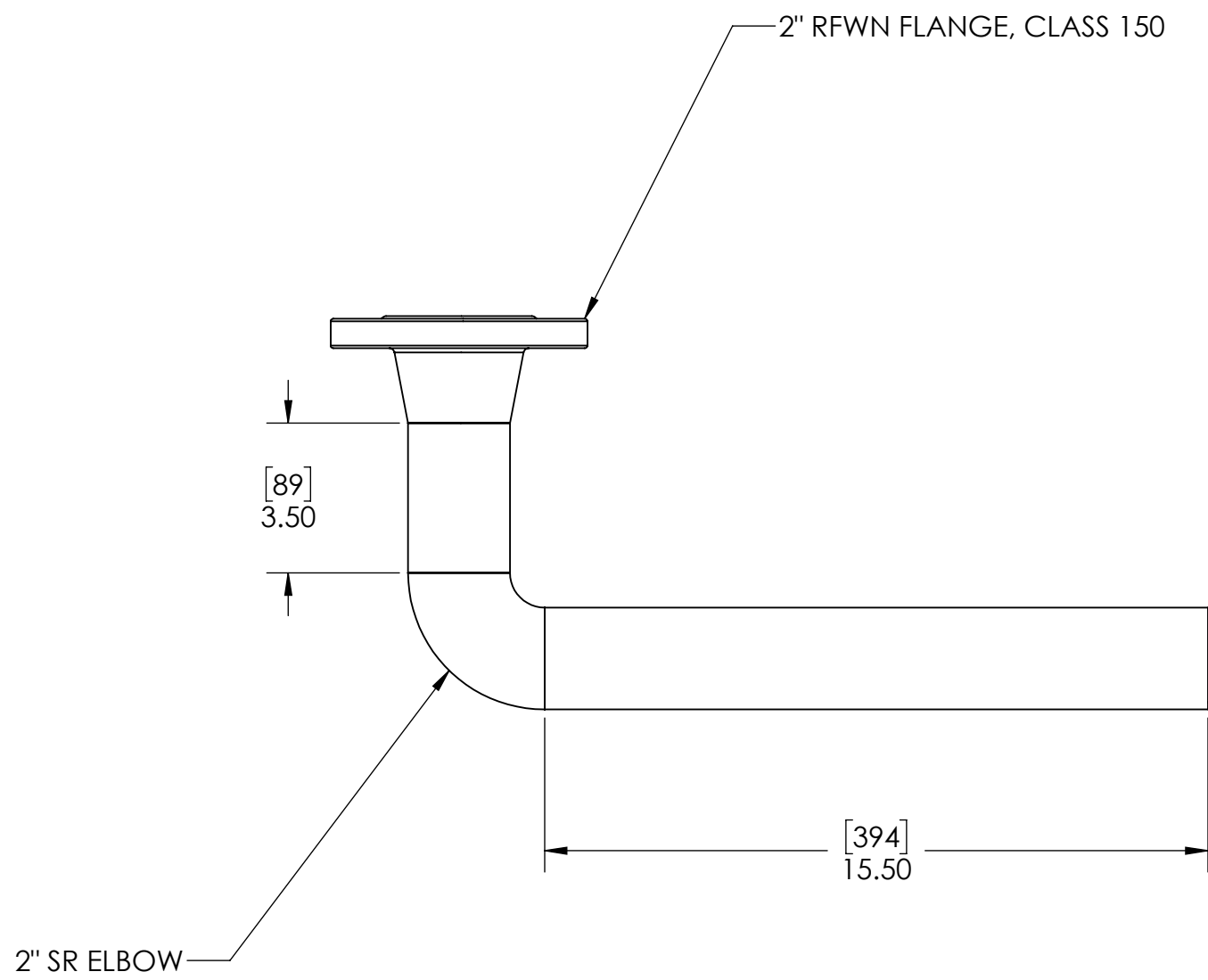

STACK-UP COMPONENTS SHOWN TO SCALE. HOWEVER, CONTRACTOR SHOULD PROTOTYPE AND FIELD TEST FIRST ARTICLE BEFORE FABRICATING REMAINING STACK-UPS.

[MILLIMETERS]  
INCHES

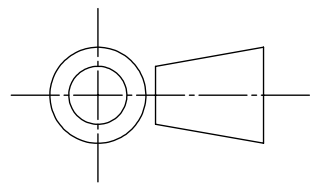

APPROVALS	DATE
DRAWN DLL	08-27-24
CHECKED DLL	08-27-24
APPROVED CDM	08-27-24
SHEET 3 OF 3	
SCALE: 1:4	SIZE: B

**USS, LLC**  
 PHONE: (260) 693-1172 FAX: (260) 693-1178  
 WEB SITE: WWW.USSPECIALISTS.COM

**USS24-20x20-36D**  
**HPVSA(2)[4]**  
**STACK-UP**

THE INFORMATION ON THIS DRAWING IS PROPRIETARY AND IS NOT TO BE REVEALED TO THIRD PARTIES WITHOUT WRITTEN CONSENT OF A CORPORATE OFFICER OF USS, LLC.