

TOP VIEW

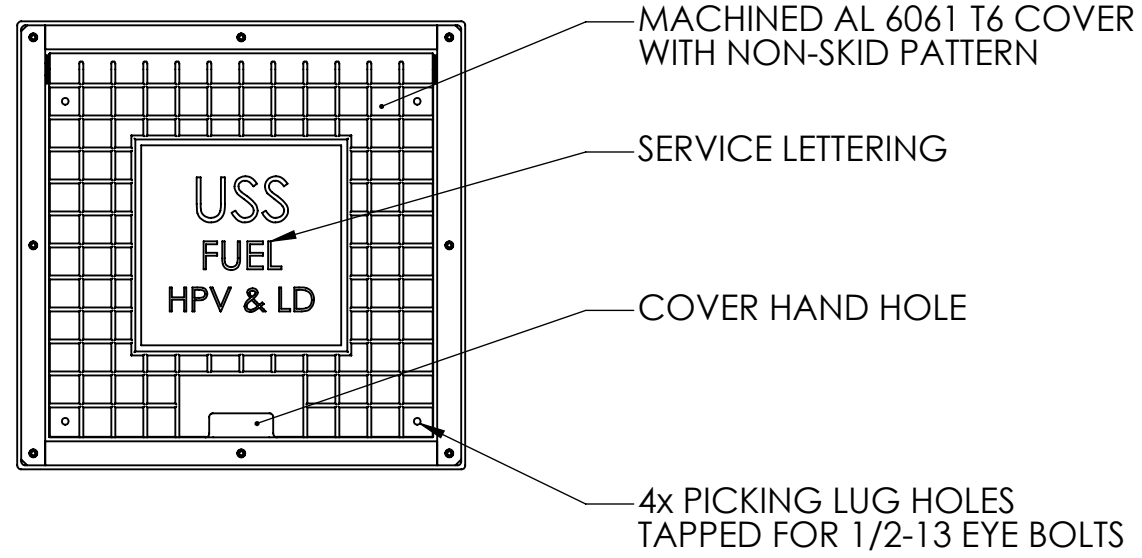

PLAN VIEW

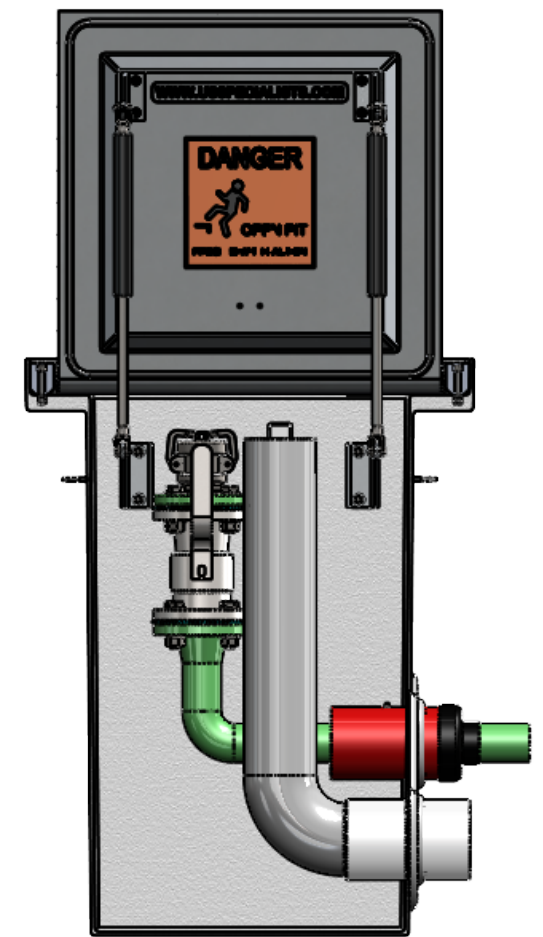

FRONT CUT VIEW

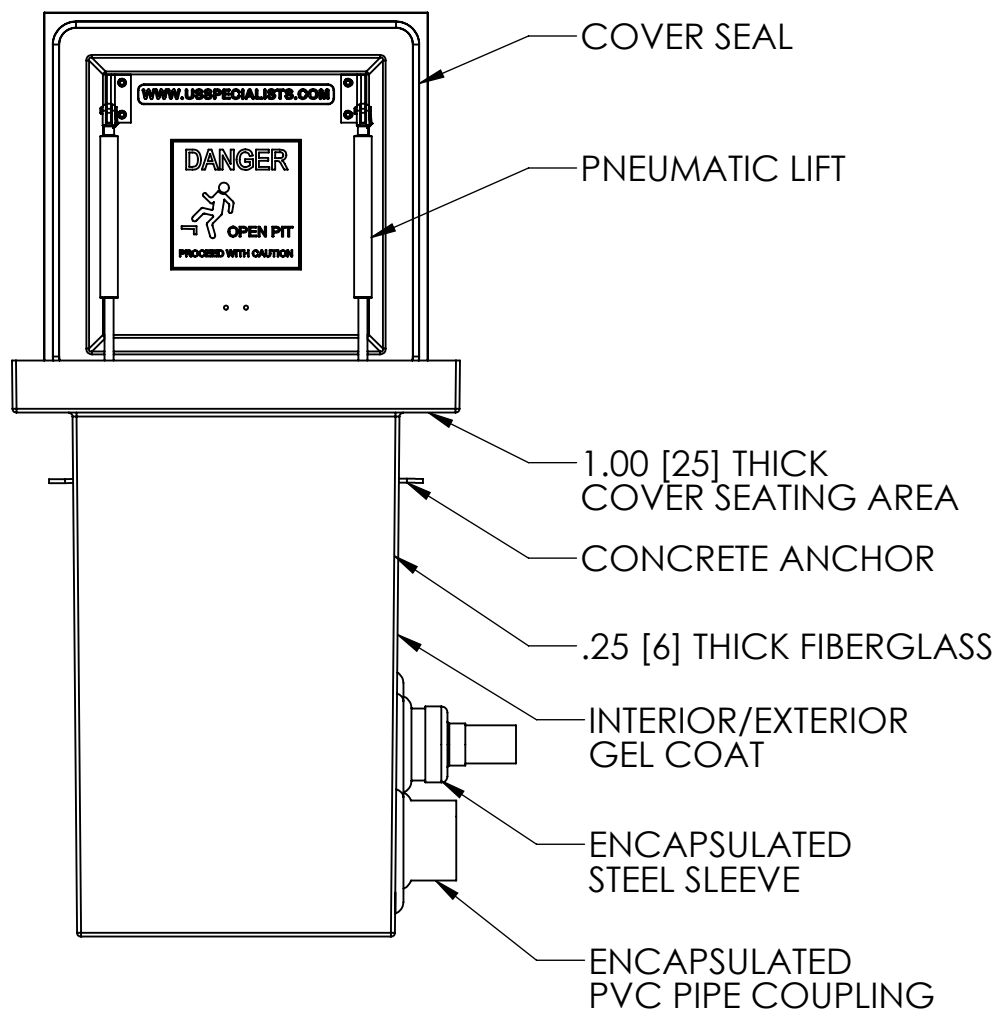

FRONT VIEW

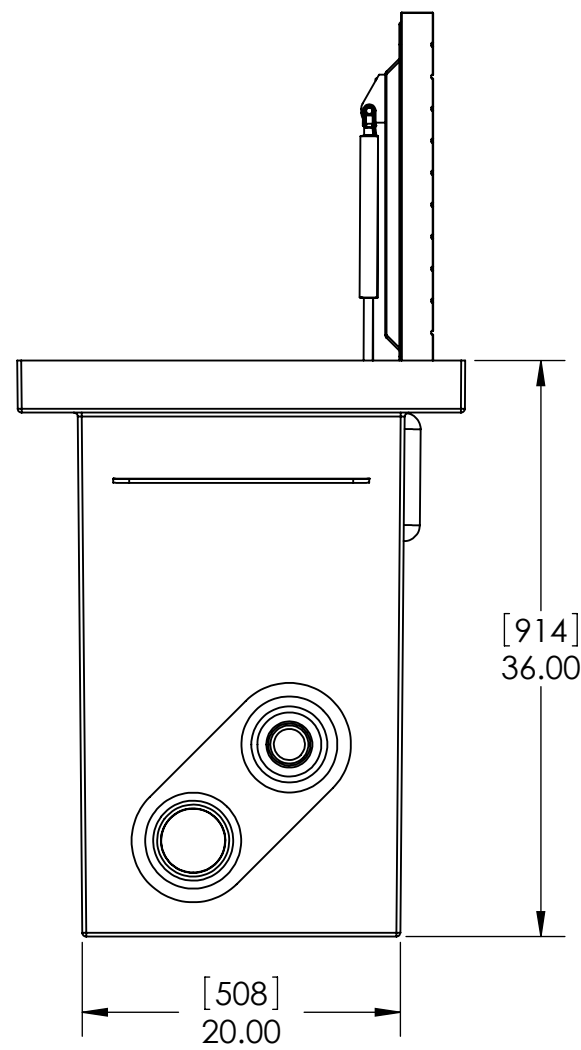

SIDE VIEW

[MILLIMETERS]
INCHES

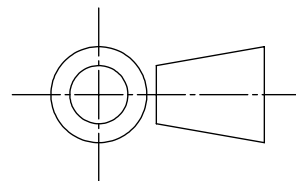

INTERNAL COMPONENTS SHOWN FOR REFERENCE.
NO INTERNAL COMPONENTS PROVIDED



APPROVALS	DATE
DRAWN DLL	08-15-24
CHECKED DLL	08-15-24
APPROVED CDM	08-15-24
SHEET 1 OF 3	
SCALE: 1:12	SIZE: B

USS, LLC
 PHONE: (260) 693-1172 FAX: (260) 693-1178
 WEB SITE: WWW.USSPECIALISTS.COM

USS24-20x20-36D
HPVSE(2)[4]&LDSE[4]
3 VIEW, PLAN, CUT

THE INFORMATION ON THIS DRAWING IS PROPRIETARY AND IS NOT TO BE REVEALED TO THIRD PARTIES WITHOUT WRITTEN CONSENT OF A CORPORATE OFFICER OF USS, LLC.

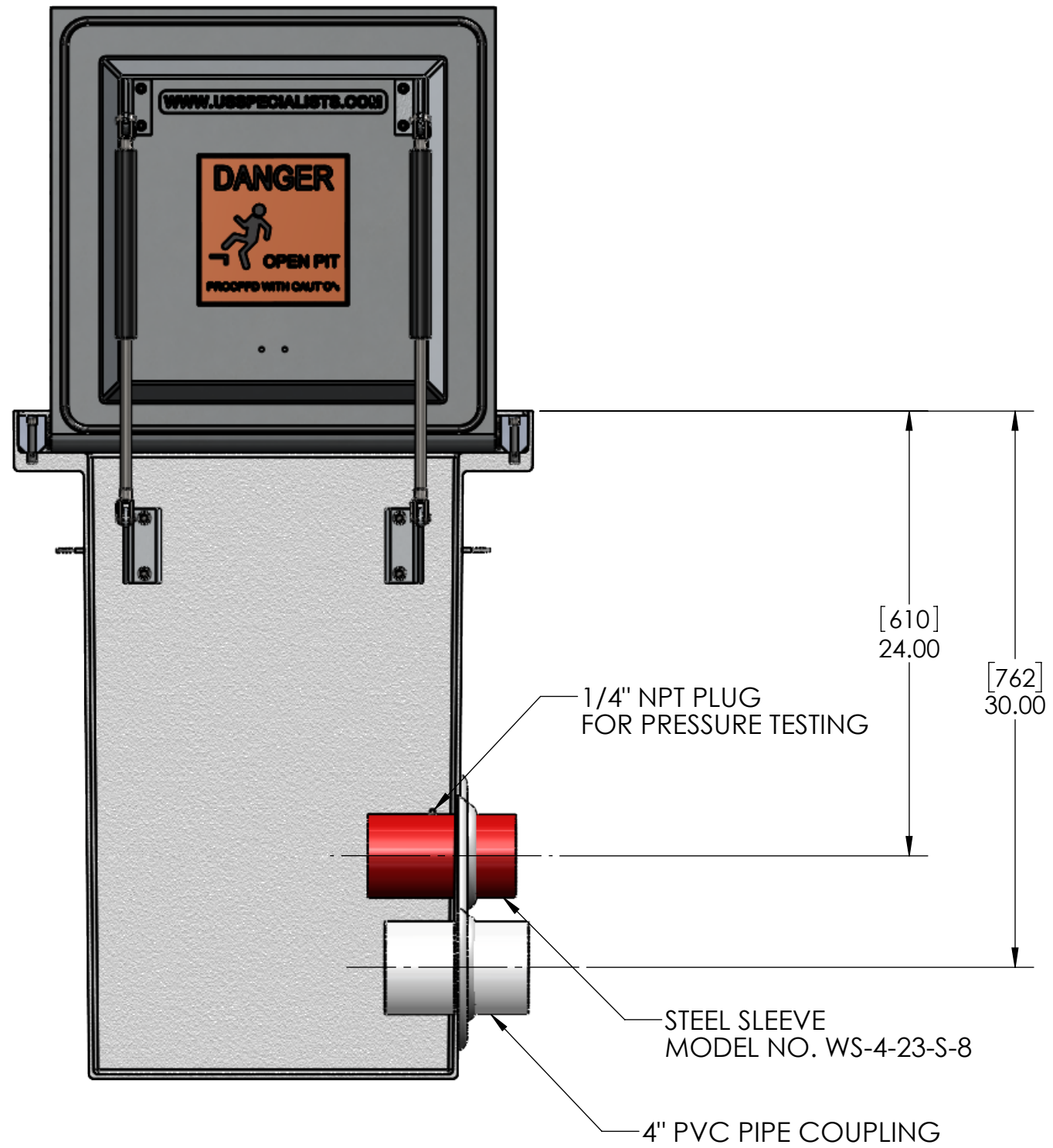

QUANTITY _____

RELEASE FOR FABRICATION

NAME _____ SIGNATURE _____

DATE _____ COMPANY _____

[MILLIMETERS]
INCHES

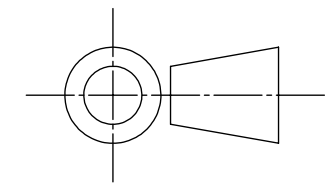

APPROVALS	DATE
DRAWN DLL	08-15-24
CHECKED DLL	08-15-24
APPROVED CDM	08-15-24
SHEET 2 OF 3	
SCALE: 1:8	SIZE: B

USS, LLC
PHONE: (260) 693-1172 FAX: (260) 693-1178
WEB SITE: WWW.USSPECIALISTS.COM

USS24-20x20-36D
HPVSE(2)[4]&LDSE[4]
SUBMITTAL

THE INFORMATION ON THIS DRAWING IS PROPRIETARY AND IS NOT TO BE REVEALED TO THIRD PARTIES WITHOUT WRITTEN CONSENT OF A CORPORATE OFFICER OF USS, LLC.

EMPTY PIT: 291 LB [132 KG]

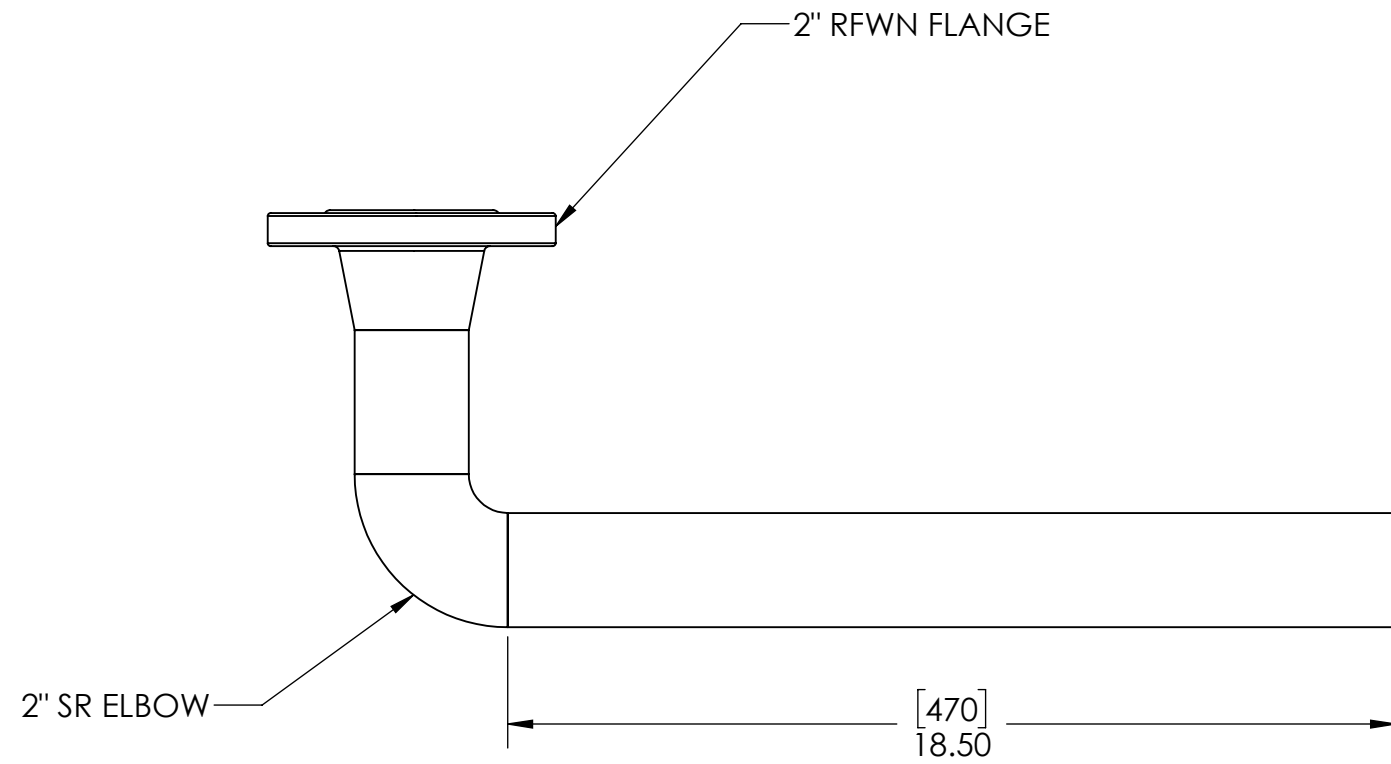
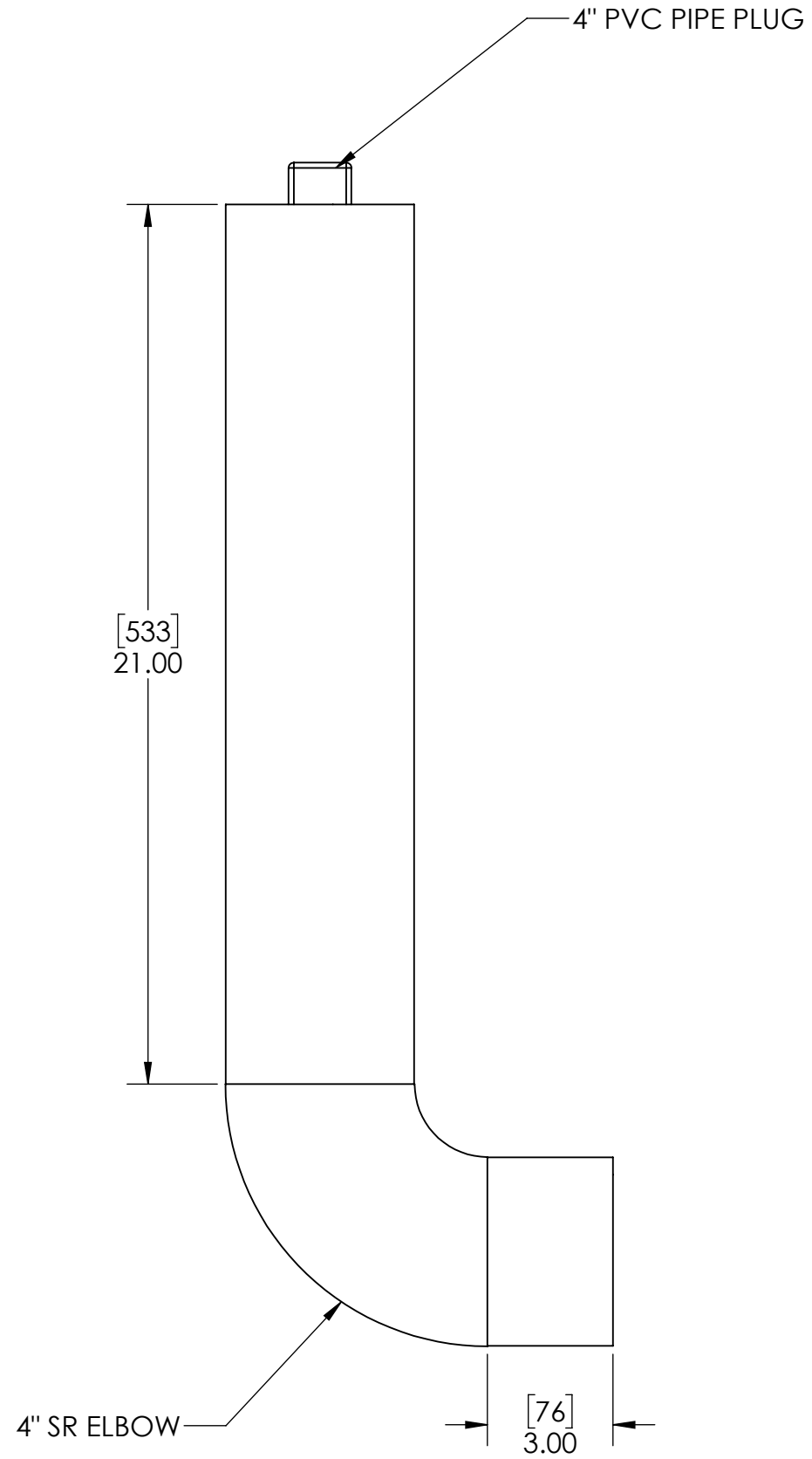

STACK-UP COMPONENTS SHOWN TO SCALE. HOWEVER, CONTRACTOR SHOULD PROTOTYPE AND FIELD TEST FIRST ARTICLE BEFORE FABRICATING REMAINING STACK-UPS.

[MILLIMETERS]
INCHES

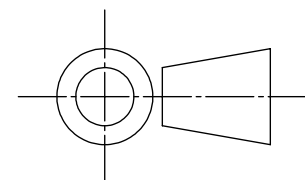

APPROVALS	DATE
DRAWN DLL	08-15-24
CHECKED DLL	08-15-24
APPROVED CDM	08-15-24
SHEET 3 OF 3	
SCALE: 1:4	SIZE: B

USS, LLC
 PHONE: (260) 693-1172 FAX: (260) 693-1178
 WEB SITE: WWW.USSPECIALISTS.COM

USS24-20x20-36D
HPVSE(2)[4]&LDSE[4]
STACK-UP

THE INFORMATION ON THIS DRAWING IS PROPRIETARY AND IS NOT TO BE REVEALED TO THIRD PARTIES WITHOUT WRITTEN CONSENT OF A CORPORATE OFFICER OF USS, LLC.