

TOP VIEW

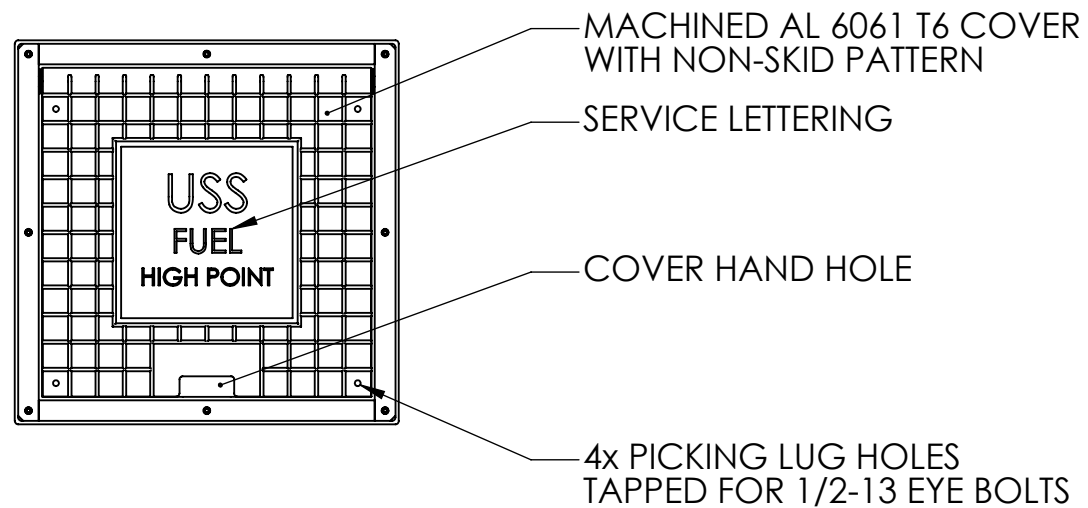

PLAN VIEW

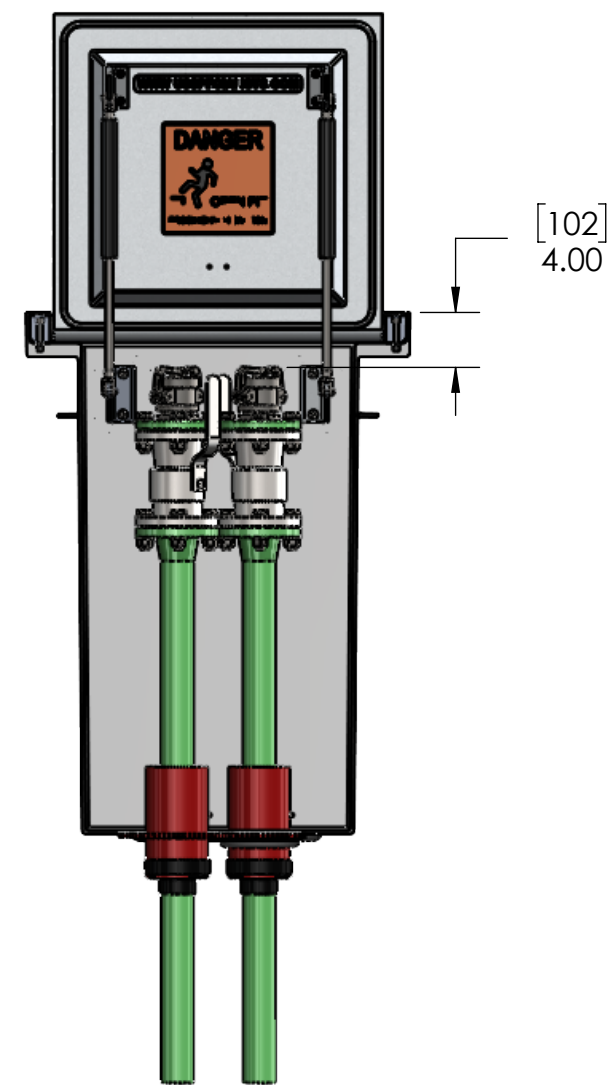

FRONT CUT VIEW

INTERNAL COMPONENTS SHOWN FOR REFERENCE. NO INTERNAL COMPONENTS PROVIDED

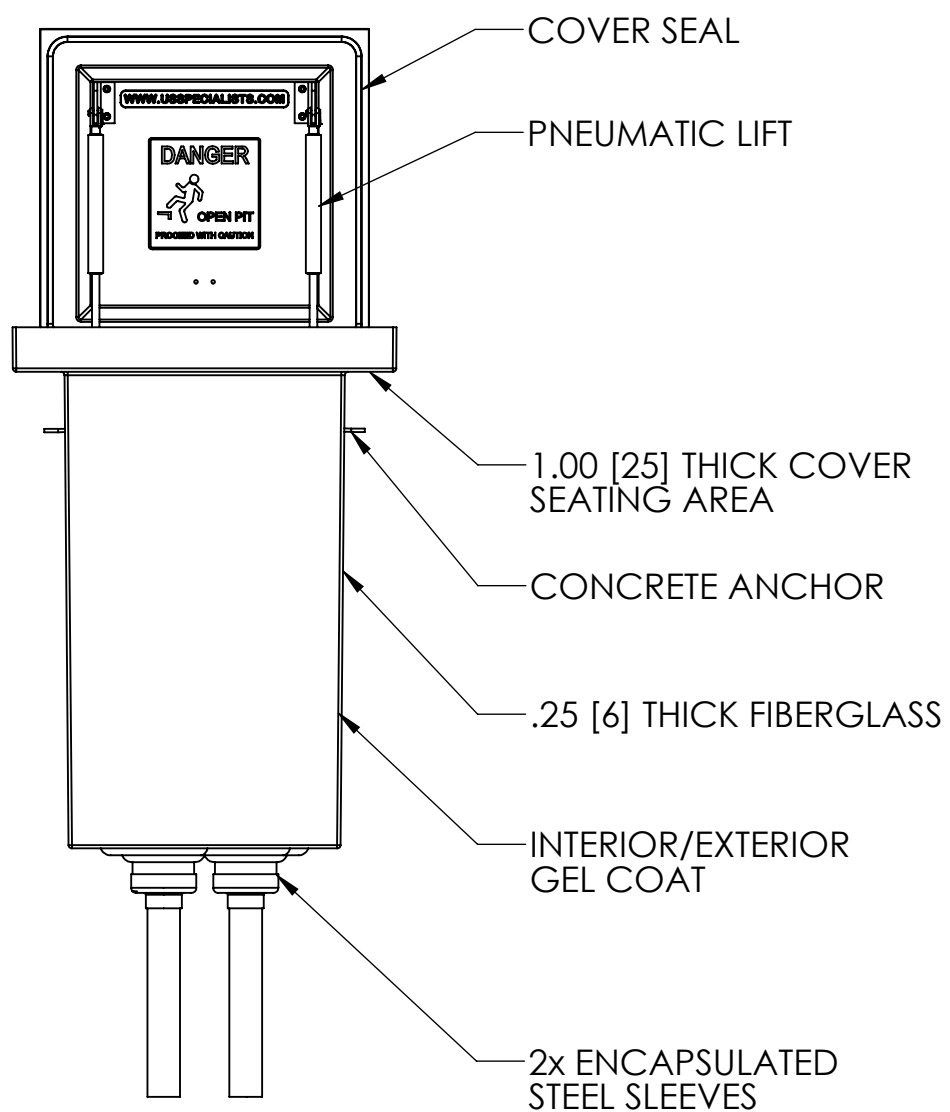

FRONT VIEW

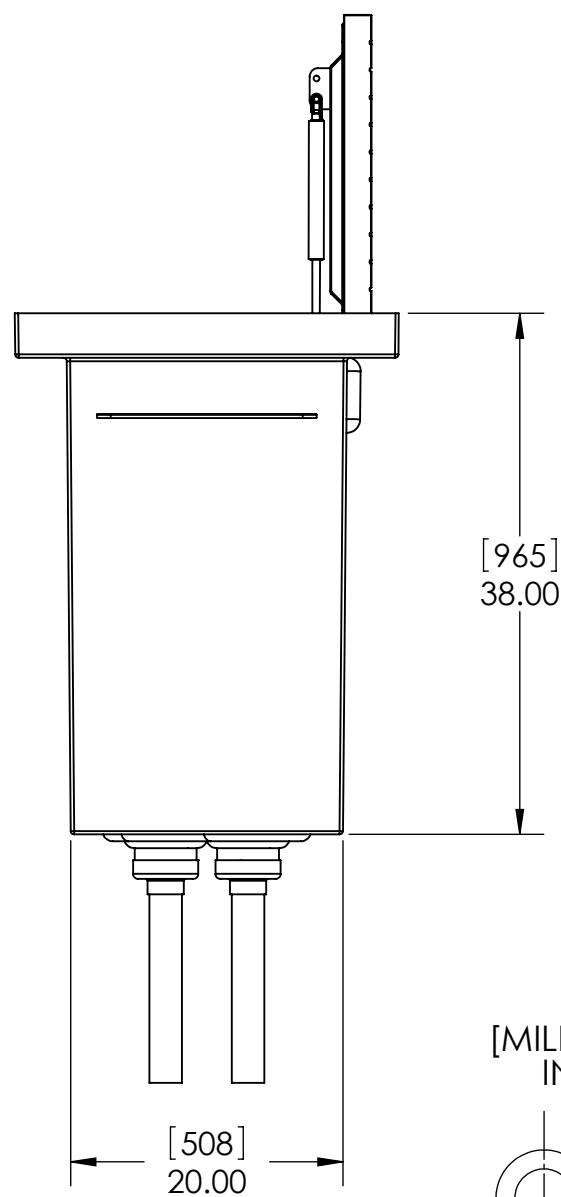

SIDE VIEW

[MILLIMETERS]  
INCHES

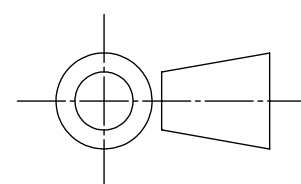

APPROVALS	DATE
DRAWN DLL	05-16-24
CHECKED DLL	05-16-24
APPROVED CDM	05-16-24
SHEET 1 OF 3	
SCALE: 1:14	SIZE: B

**USS, LLC**  
 PHONE: (260) 693-1172 FAX: (260) 693-1178  
 WEB SITE: WWW.USSPECIALISTS.COM

**USS24-20x20-38D**  
**(2)HPVBA(2)[4]**  
**3-VIEW, PLAN, CUT**

THE INFORMATION ON THIS DRAWING IS PROPRIETARY AND IS NOT TO BE REVEALED TO THIRD PARTIES WITHOUT WRITTEN CONSENT OF A CORPORATE OFFICER OF USS, LLC.

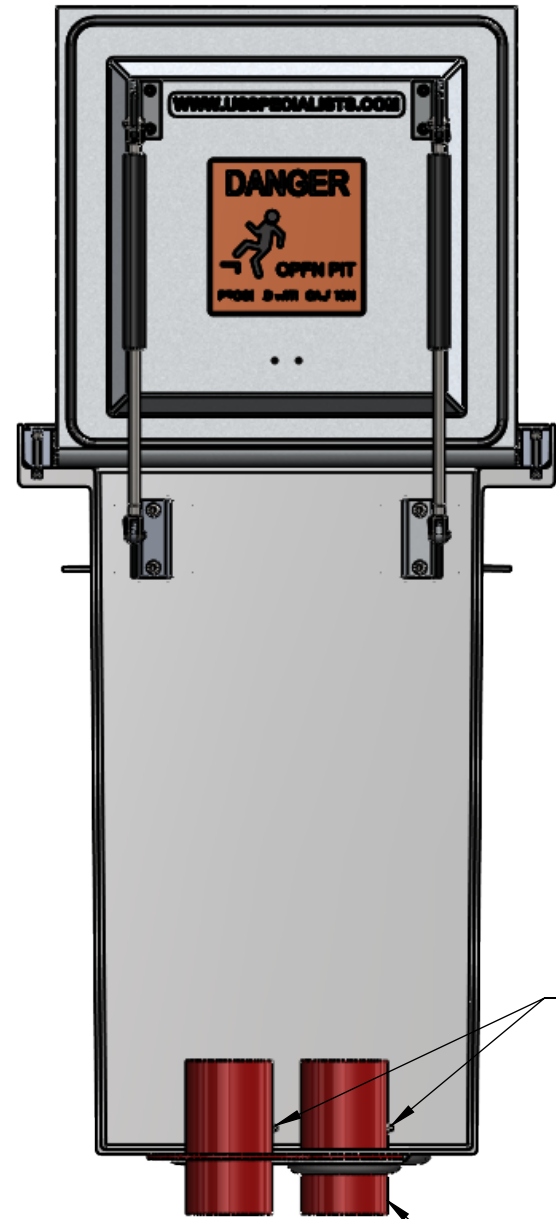

1/4" NPT PIPE PLUGS

2x STEEL SLEEVES  
MODEL NO. WS-4-23-S-8

[MILLIMETERS]  
INCHES

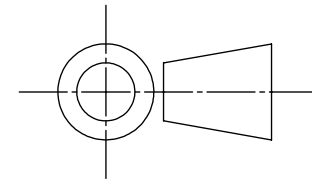

EMPTY PIT: 302 LB [137 KG]

QUANTITY \_\_\_\_\_

**RELEASE FOR FABRICATION**

NAME \_\_\_\_\_ SIGNATURE \_\_\_\_\_

DATE \_\_\_\_\_ COMPANY \_\_\_\_\_



APPROVALS	DATE
DRAWN DLL	05-16-24
CHECKED DLL	05-16-24
APPROVED CDM	05-16-24
SHEET 2 OF 3	
SCALE: 1:10	SIZE: B

**USS, LLC**  
PHONE: (260) 693-1172 FAX: (260) 693-1178  
WEB SITE: WWW.USSPECIALISTS.COM

**USS24-20x20-38D**  
**(2)HPVBA(2)[4]**  
**SUBMITTAL**

THE INFORMATION ON THIS DRAWING IS PROPRIETARY AND IS NOT TO BE REVEALED TO THIRD PARTIES WITHOUT WRITTEN CONSENT OF A CORPORATE OFFICER OF USS, LLC.

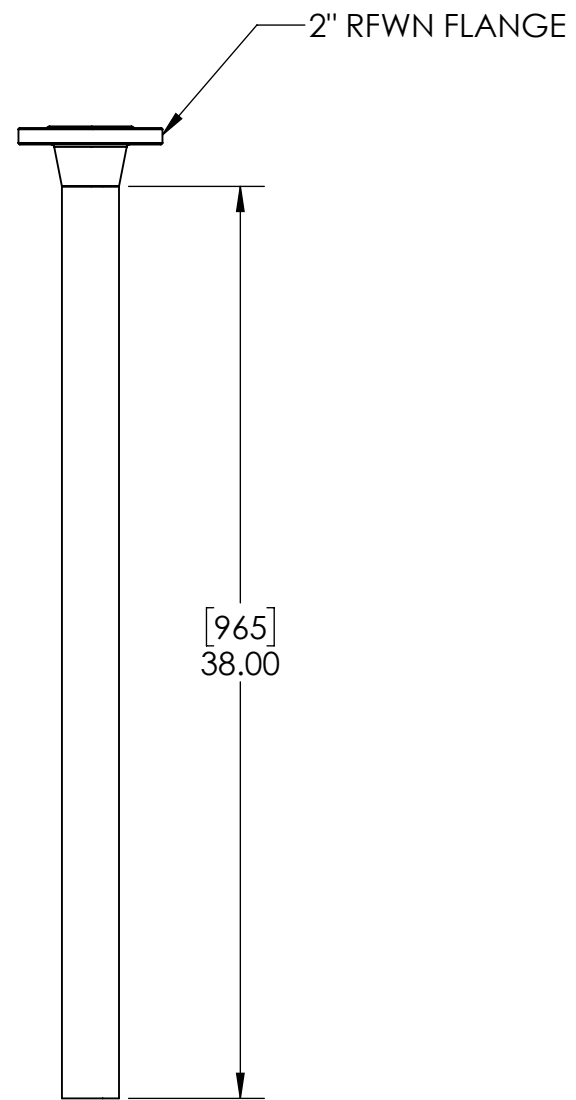

STACK-UP COMPONENTS SHOWN TO SCALE. HOWEVER, CONTRACTOR SHOULD PROTOTYPE AND FIELD TEST FIRST ARTICLE BEFORE FABRICATING REMAINING STACK-UPS.

[MILLIMETERS]  
INCHES

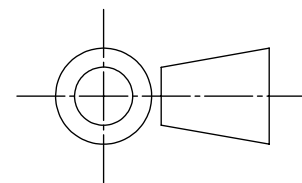

APPROVALS	DATE
DRAWN DLL	05-16-24
CHECKED DLL	05-16-24
APPROVED CDM	05-16-24
SHEET 3 OF 3	
SCALE: 1:10	SIZE: B

**USS, LLC**  
 PHONE: (260) 693-1172 FAX: (260) 693-1178  
 WEB SITE: WWW.USSPECIALISTS.COM

**USS24-20x20-38D**  
**(2)HPVBA(2)[4]**  
**STACK-UP**

THE INFORMATION ON THIS DRAWING IS PROPRIETARY AND IS NOT TO BE REVEALED TO THIRD PARTIES WITHOUT WRITTEN CONSENT OF A CORPORATE OFFICER OF USS, LLC.