

TOP VIEW

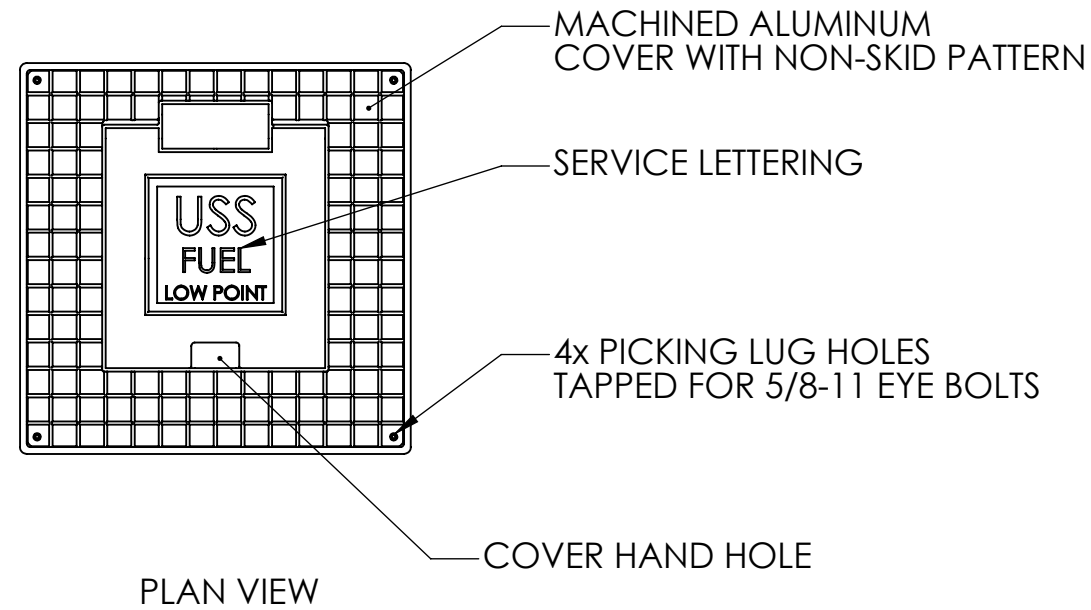

PLAN VIEW

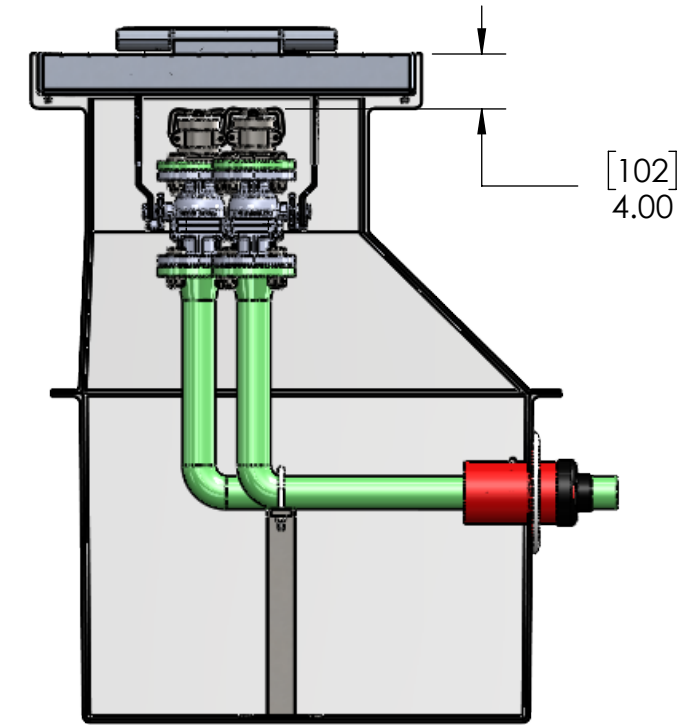

FRONT CUT VIEW

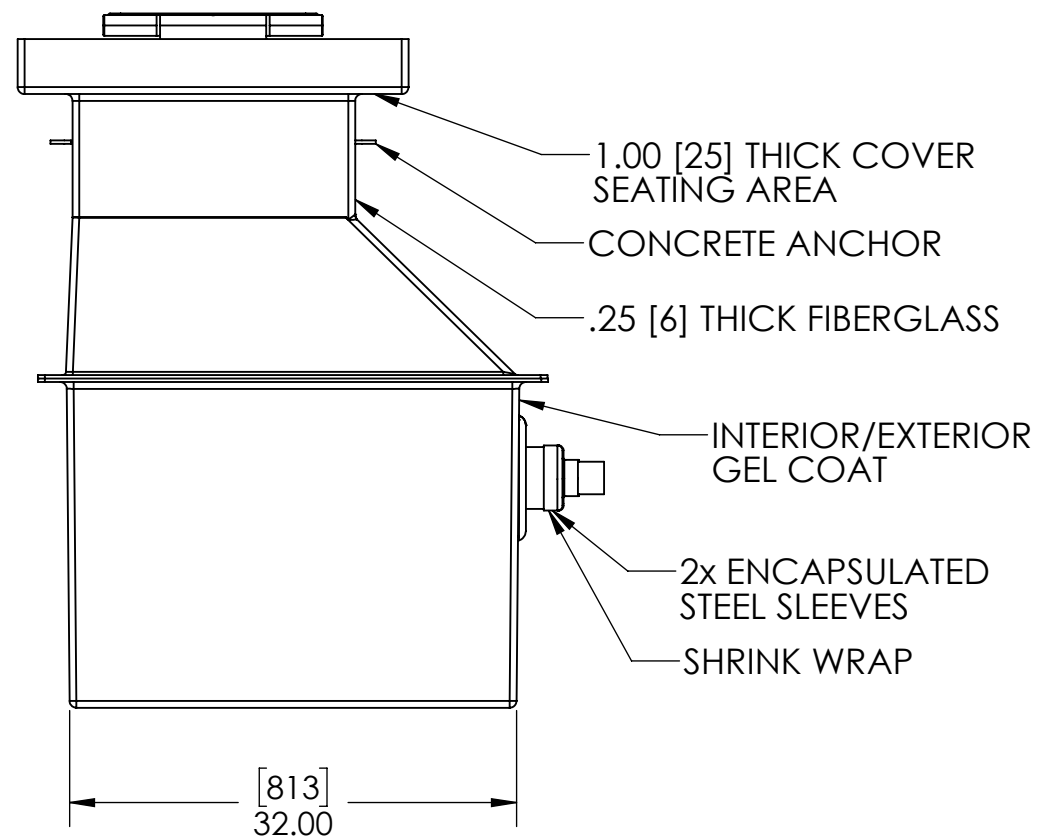

FRONT VIEW

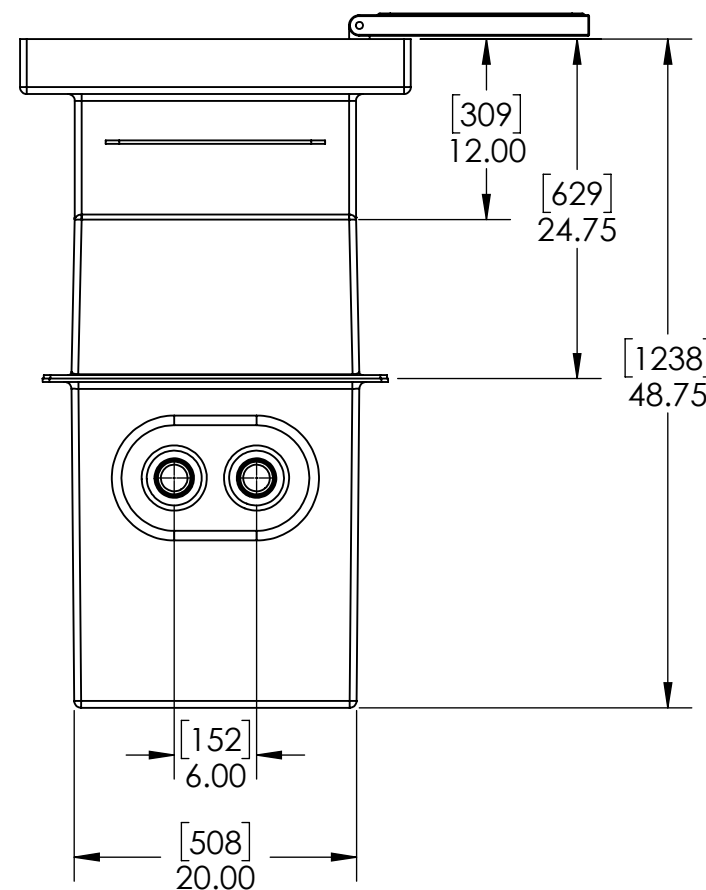

SIDE VIEW

INTERNAL COMPONENTS SHOWN FOR REFERENCE.  
NO INTERNAL COMPONENTS PROVIDED.



APPROVALS	DATE
DRAWN DLL	06-28-24
CHECKED DLL	06-28-24
APPROVED CDM	06-28-24
SHEET 1 OF 7	
SCALE: 1:14	SIZE: B

**USS, LLC**  
PHONE: (260) 693-1172 FAX: (260) 693-1178  
WEB SITE: WWW.USSPECIALISTS.COM

**USS27.5(14)-20x20-20x32-48.75D**  
**(2)LPD(2)[4]**  
**3 VIEW, PLAN, CUT**

THE INFORMATION ON THIS DRAWING IS PROPRIETARY AND IS NOT TO BE REVEALED TO THIRD PARTIES WITHOUT WRITTEN CONSENT OF A CORPORATE OFFICER OF USS, LLC.

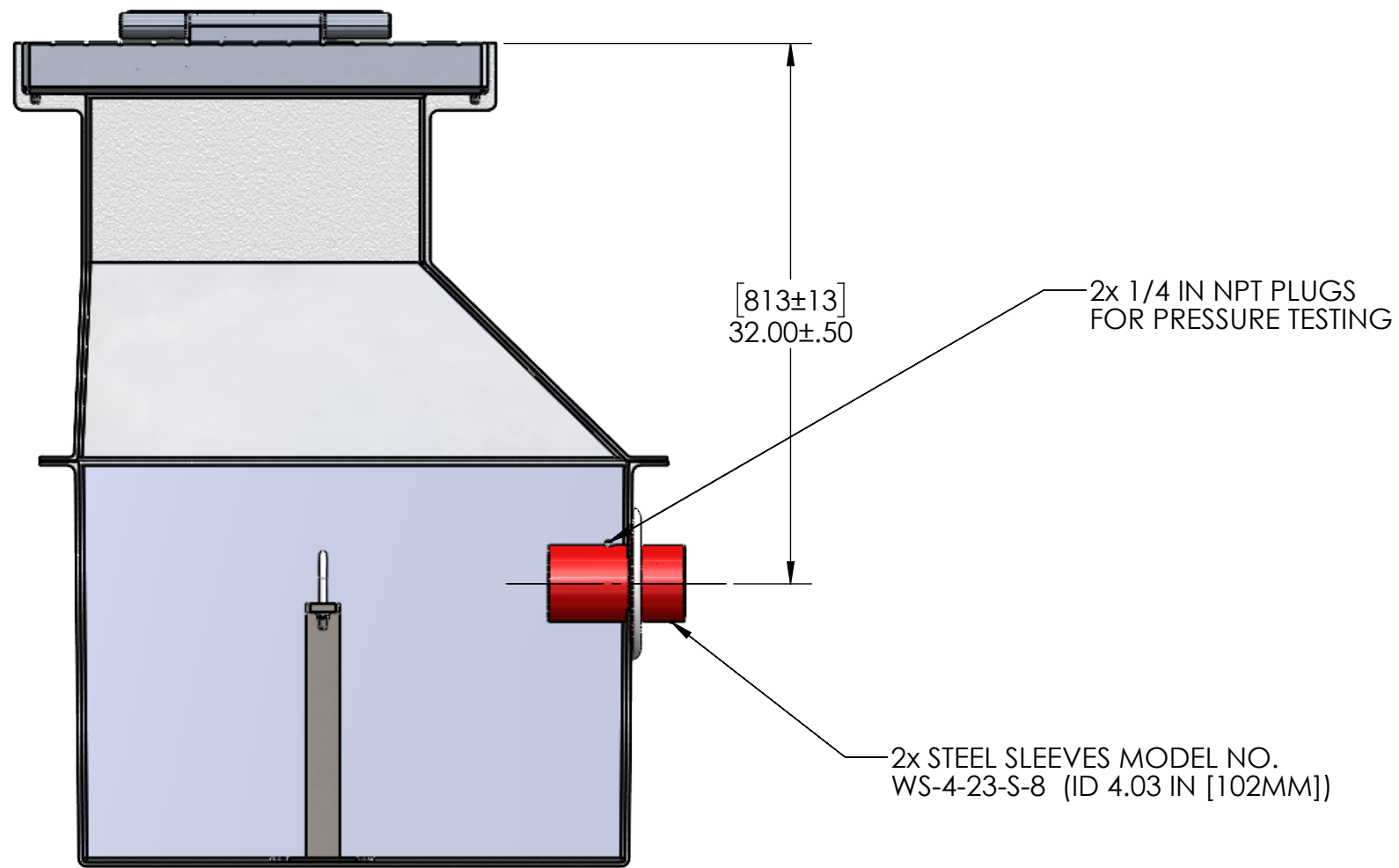

QUANTITY	_____
----------	-------

RELEASE FOR FABRICATION	
NAME _____	SIGNATURE _____
DATE _____	COMPANY _____

EMPTY PIT: 402 LB [182 KG]



APPROVALS	DATE
DRAWN DLL	06-28-24
CHECKED DLL	06-28-24
APPROVED CDM	06-28-24
SHEET 2 OF 7	
SCALE: 1:10	SIZE: B

**USS, LLC**  
 PHONE: (260) 693-1172 FAX: (260) 693-1178  
 WEB SITE: WWW.USSPECIALISTS.COM  
**USS27.5(14)-20x20-20x32-48.75D**  
**(2)LPD(2)[4]**  
**SUBMITTAL**  
THE INFORMATION ON THIS DRAWING IS PROPRIETARY AND IS NOT TO BE REVEALED TO THIRD PARTIES WITHOUT WRITTEN CONSENT OF A CORPORATE OFFICER OF USS, LLC.

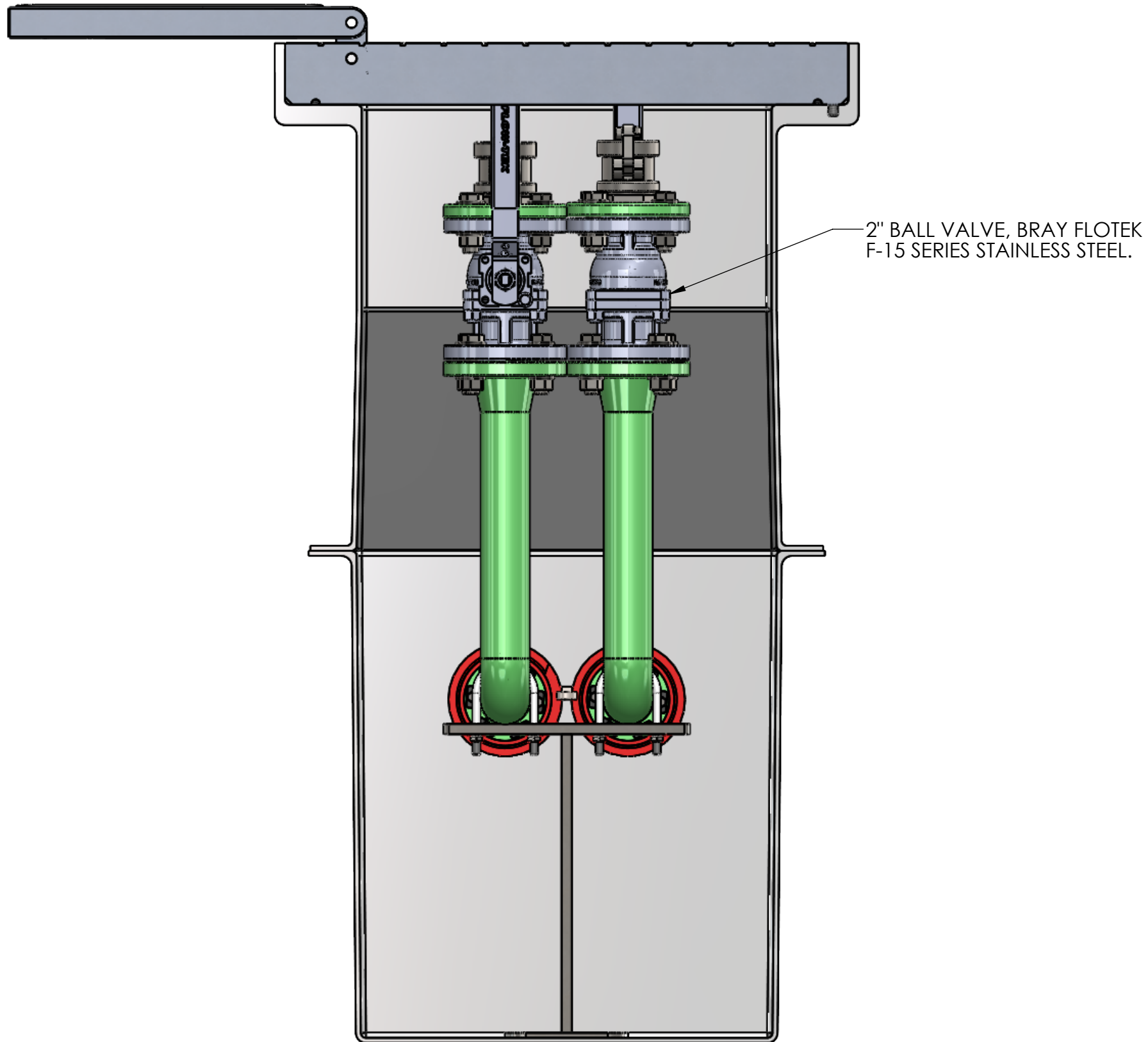

INTERNAL COMPONENTS SHOWN FOR REFERENCE.  
NO INTERNAL COMPONENTS PROVIDED.

**RELEASE FOR FABRICATION**

NAME \_\_\_\_\_ SIGNATURE \_\_\_\_\_  
DATE \_\_\_\_\_ COMPANY \_\_\_\_\_



Utility Systems Specialists

APPROVALS	DATE
DRAWN DLL	06-28-24
CHECKED DLL	06-28-24
APPROVED CDM	06-28-24
SHEET 3 OF 7	

**USS, LLC**  
PHONE: (260) 693-1172 FAX: (260) 693-1178  
WEB SITE: WWW.USSPECIALISTS.COM  
**USS27.5(14)-20x20-20x32-48.75D**  
**(2)LPD(2)[4]**  
**SIDE CUT VIEW**

SCALE: 1:6 SIZE: B

THE INFORMATION ON THIS DRAWING IS PROPRIETARY AND IS NOT TO BE REVEALED TO THIRD PARTIES WITHOUT WRITTEN CONSENT OF A CORPORATE OFFICER OF USS, LLC.

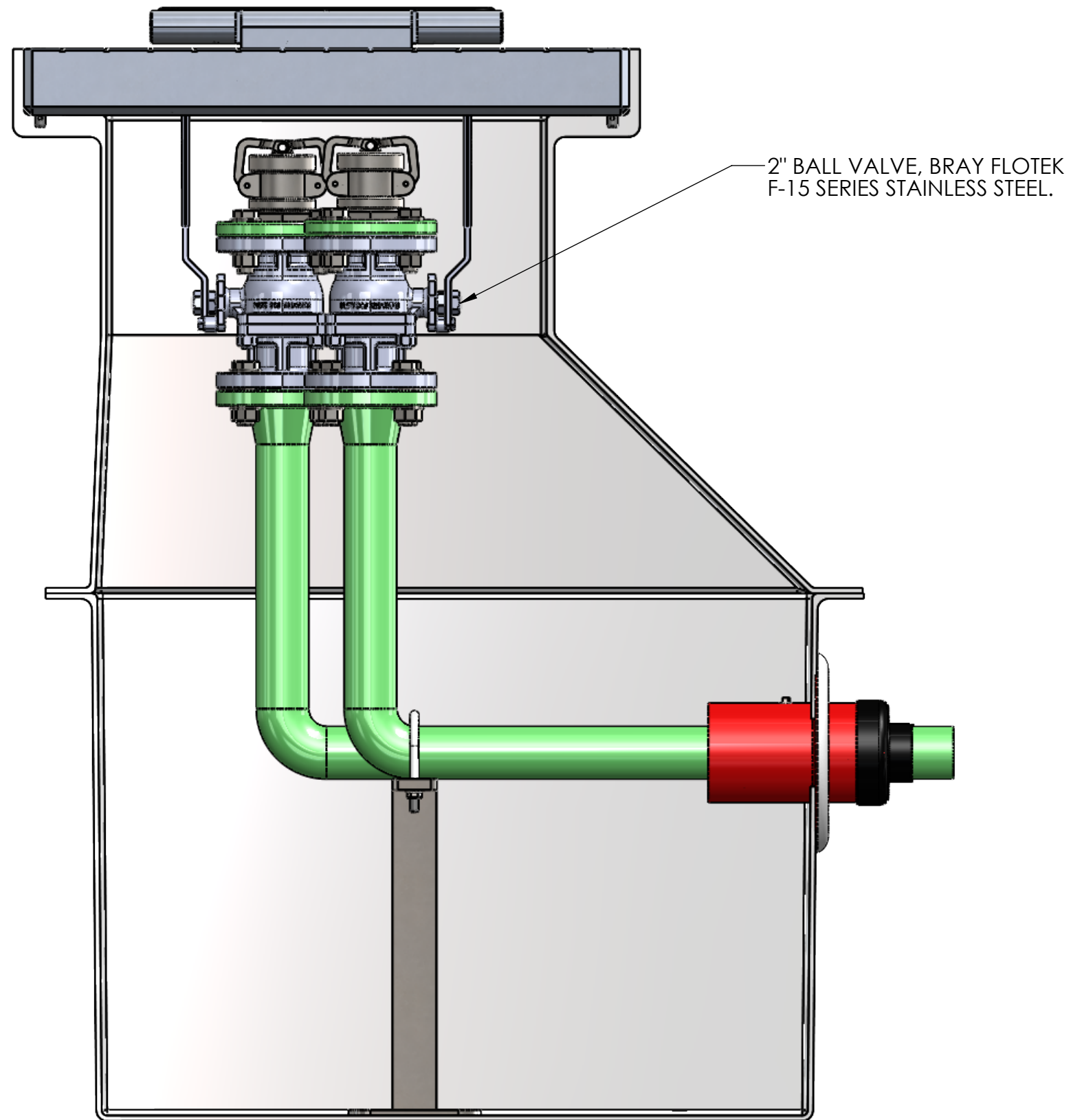

INTERNAL COMPONENTS SHOWN FOR REFERENCE.  
NO INTERNAL COMPONENTS PROVIDED.

**RELEASE FOR FABRICATION**

NAME \_\_\_\_\_ SIGNATURE \_\_\_\_\_

DATE \_\_\_\_\_ COMPANY \_\_\_\_\_



APPROVALS	DATE
DRAWN DLL	06-28-24
CHECKED DLL	06-28-24
APPROVED CDM	06-28-24
SHEET 4 OF 7	

**USS, LLC**  
PHONE: (260) 693-1172 FAX: (260) 693-1178  
WEB SITE: WWW.USSPECIALISTS.COM  
**USS27.5(14)-20x20-20x32-48.75D**  
**(2)LPD(2)[4]**  
**FRONT CUT VIEW**

SCALE: 1:6 SIZE: B

THE INFORMATION ON THIS DRAWING IS PROPRIETARY AND IS NOT TO BE REVEALED TO THIRD PARTIES WITHOUT WRITTEN CONSENT OF A CORPORATE OFFICER OF USS, LLC.

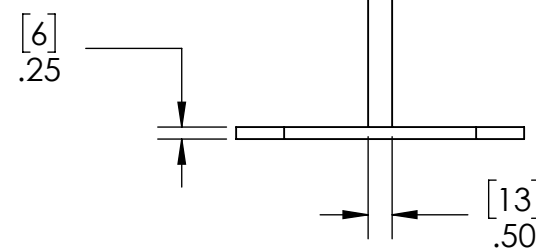
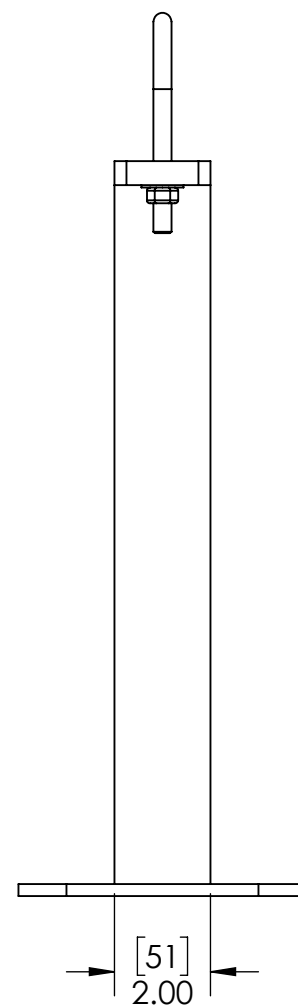
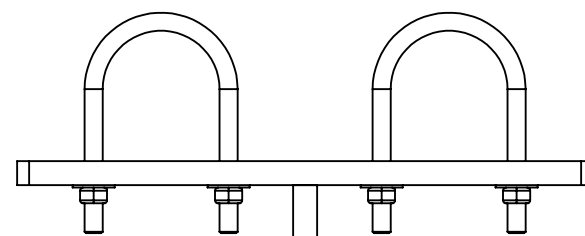
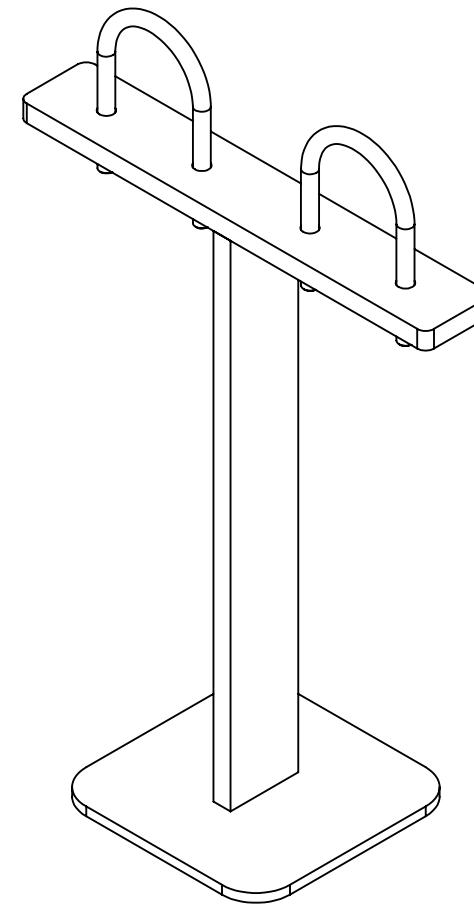
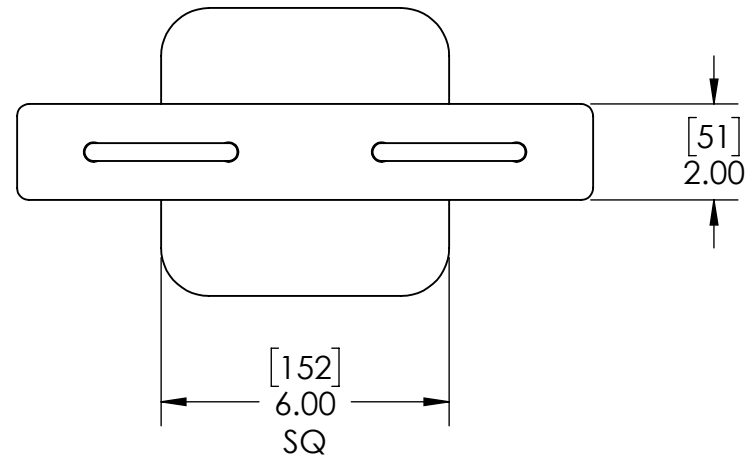

PIPE STAND COMPONENTS SHOWN TO SCALE. HOWEVER, CONTRACTOR SHOULD PROTOTYPE AND FIELD TEST FIRST ARTICLE BEFORE FABRICATING REMAINING PIPE STANDS.

**RELEASE FOR FABRICATION**

\_\_\_\_\_  
NAME SIGNATURE

\_\_\_\_\_  
DATE COMPANY

APPROVALS	DATE
DRAWN DLL	06-28-24
CHECKED DLL	06-28-24
APPROVED CDM	06-28-24
SHEET 5 OF 7	

**USS, LLC**  
PHONE: (260) 693-1172 FAX: (260) 693-1178  
WEB SITE: WWW.USSPECIALISTS.COM

**USS27.5(14)-20x20-20x32-48.75D**  
**(2)LPD(2)[4]**  
**PIPE SUPPORT**



SCALE: 1:4 SIZE: B

THE INFORMATION ON THIS DRAWING IS PROPRIETARY AND IS NOT TO BE REVEALED TO THIRD PARTIES WITHOUT WRITTEN CONSENT OF A CORPORATE OFFICER OF USS, LLC.

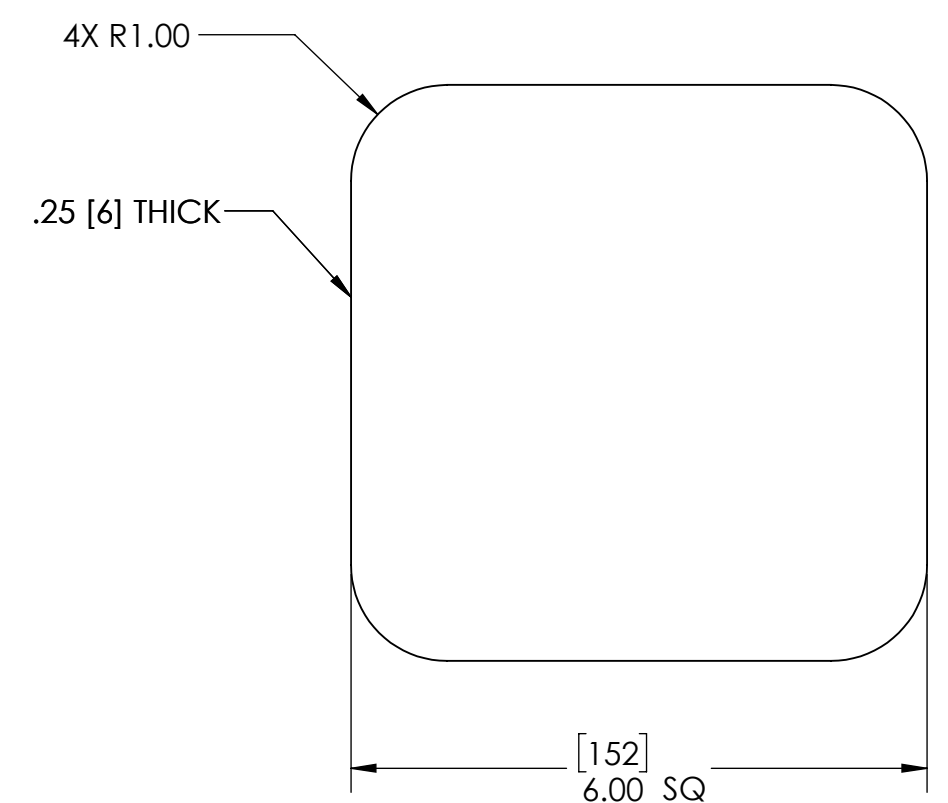
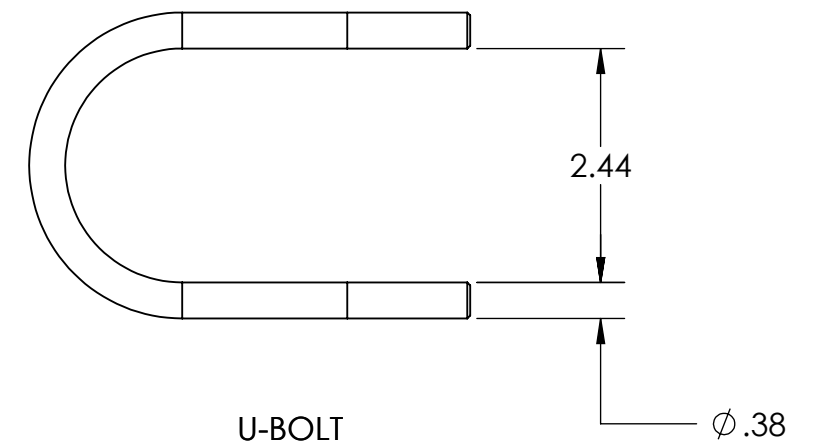
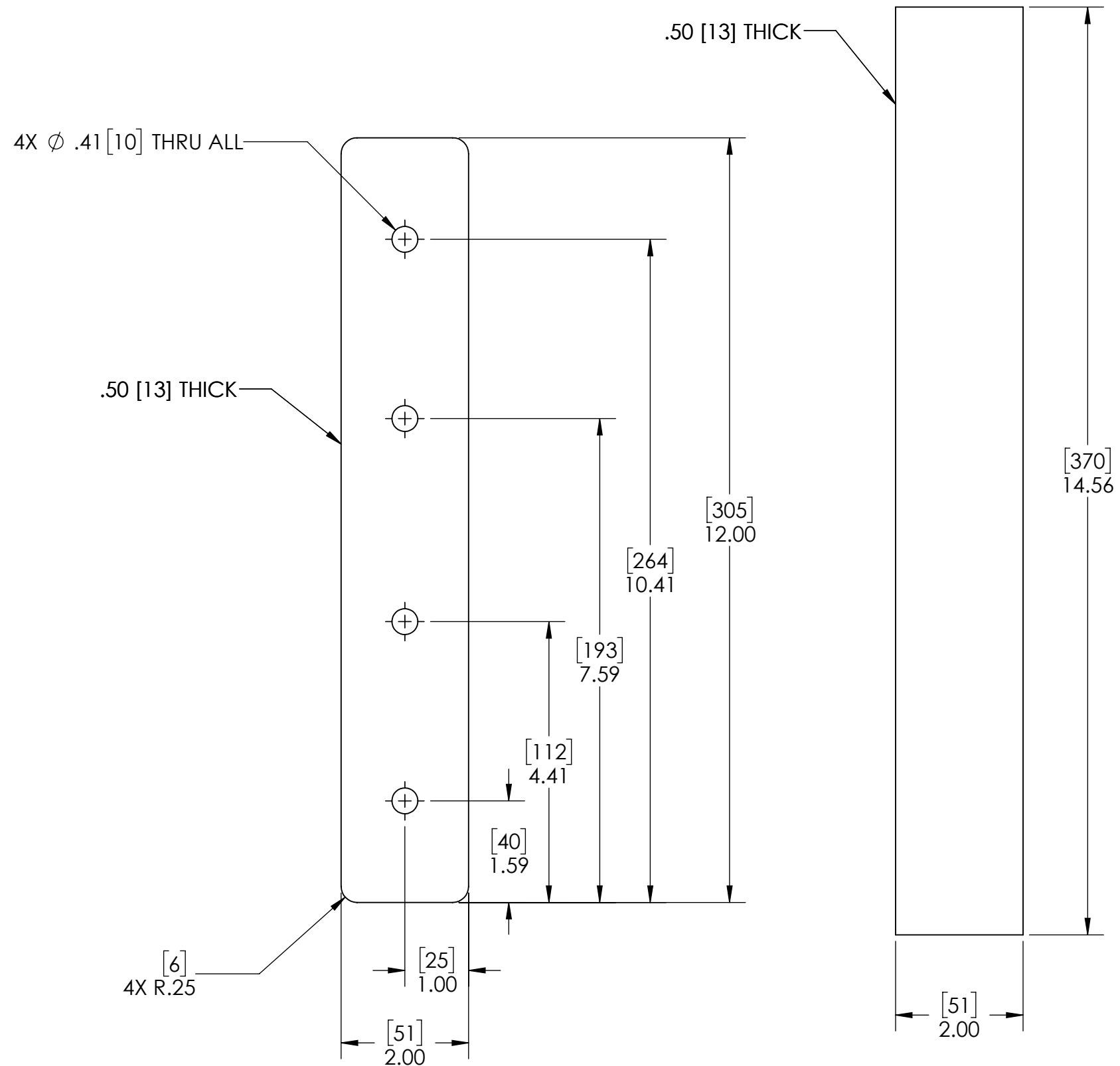

STEEL



APPROVALS	DATE
DRAWN DLL	06-28-24
CHECKED DLL	06-28-24
APPROVED CDM	06-28-24
SHEET 6 OF 7	
SCALE: 1:2	SIZE: B

**USS, LLC**  
 PHONE: (260) 693-1172 FAX: (260) 693-1178  
 WEB SITE: WWW.USSPECIALISTS.COM

**USS27.5(14)-20x20-20x32-48.75D**  
**(2)LPD(2)[4]**  
**PIPE SUPPORT PARTS**

THE INFORMATION ON THIS DRAWING IS PROPRIETARY AND IS NOT TO BE REVEALED TO THIRD PARTIES WITHOUT WRITTEN CONSENT OF A CORPORATE OFFICER OF USS, LLC.

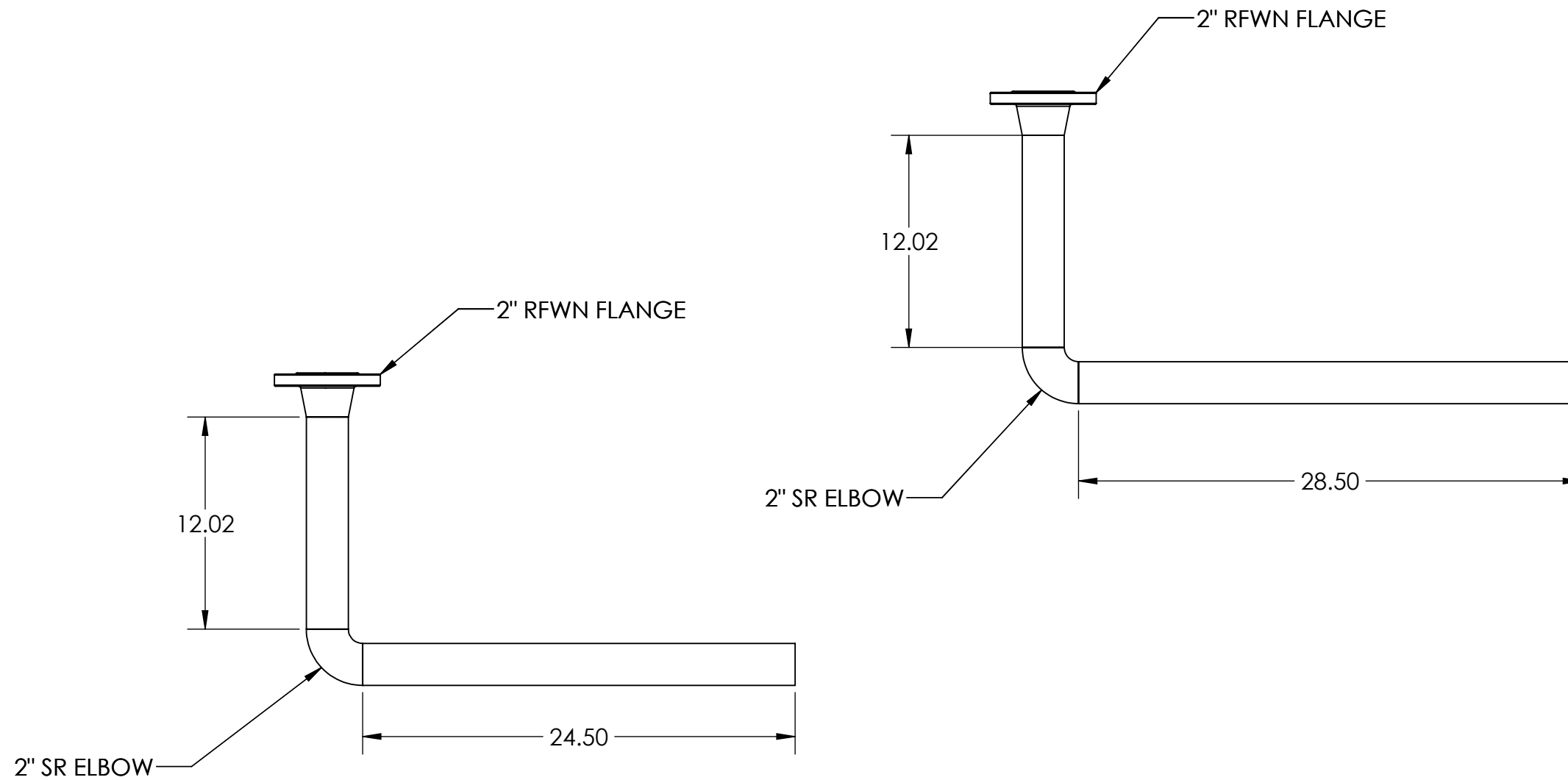

STACK-UP COMPONENTS SHOWN TO SCALE. HOWEVER, CONTRACTOR SHOULD PROTOTYPE AND FIELD TEST FIRST ARTICLE BEFORE FABRICATING REMAINING STACK-UPS.



APPROVALS	DATE	<b>USS, LLC</b> PHONE: (260) 693-1172 FAX: (260) 693-1178 WEB SITE: WWW.USSPECIALISTS.COM <b>USS27.5(14)-20x20-20x32-48.75D</b> <b>(2)LPD(2)[4]</b> <b>STACK-UPS</b>
DRAWN		
DLL	06-28-24	
CHECKED		
DLL	06-28-24	
APPROVED		
CDM	06-28-24	
SHEET 7 OF 7		
SCALE: 1:8	SIZE: B	THE INFORMATION ON THIS DRAWING IS PROPRIETARY AND IS NOT TO BE REVEALED TO THIRD PARTIES WITHOUT WRITTEN CONSENT OF A CORPORATE OFFICER OF USS, LLC.