

TOP VIEW

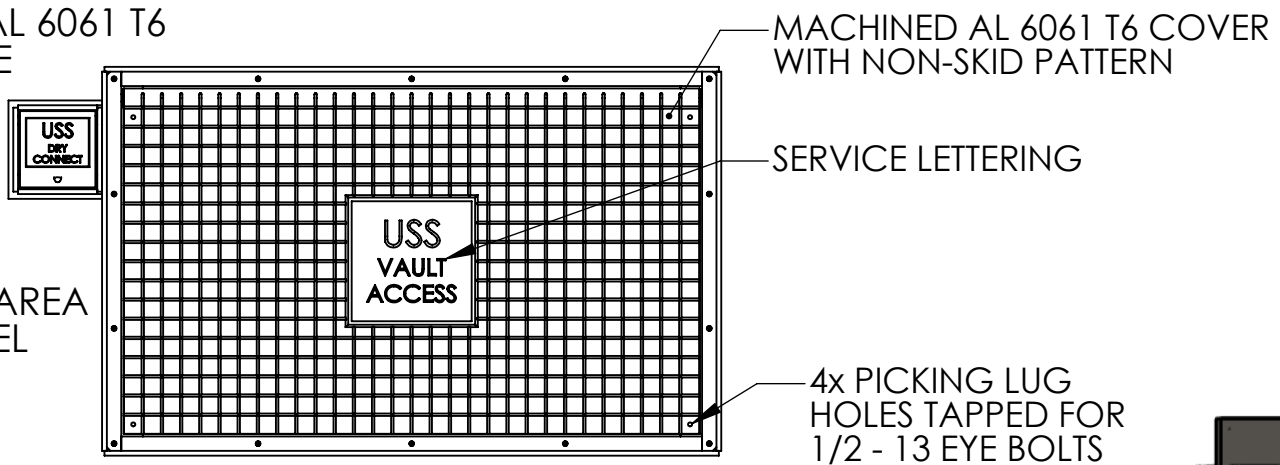

PLAN VIEW

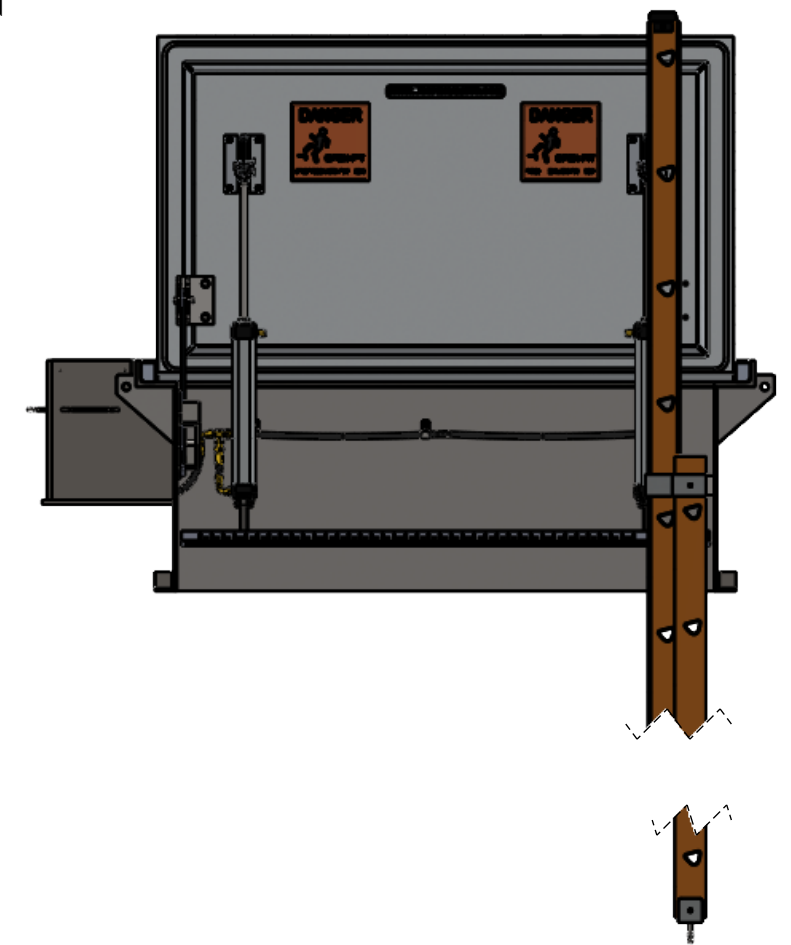

FRONT CUT VIEW

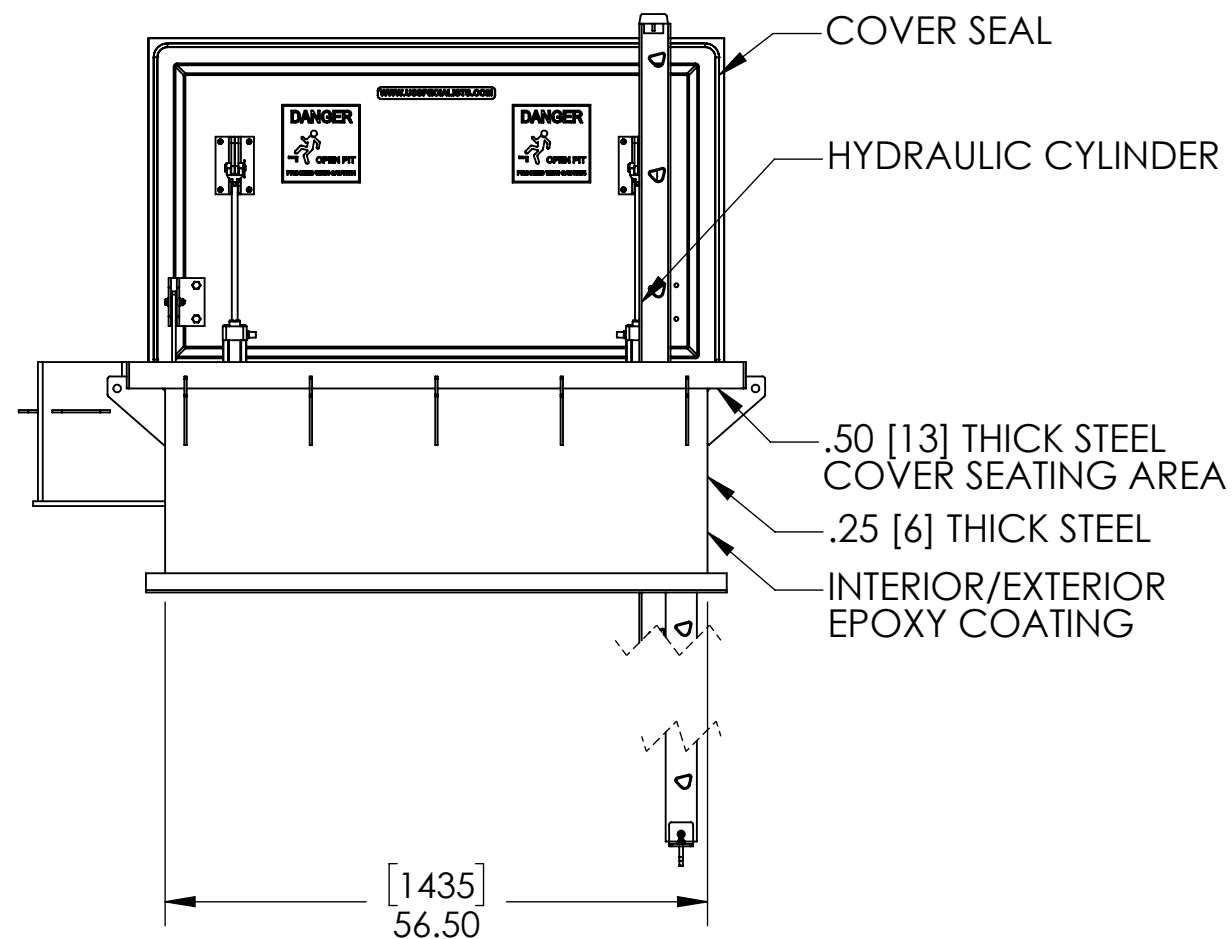

FRONT VIEW

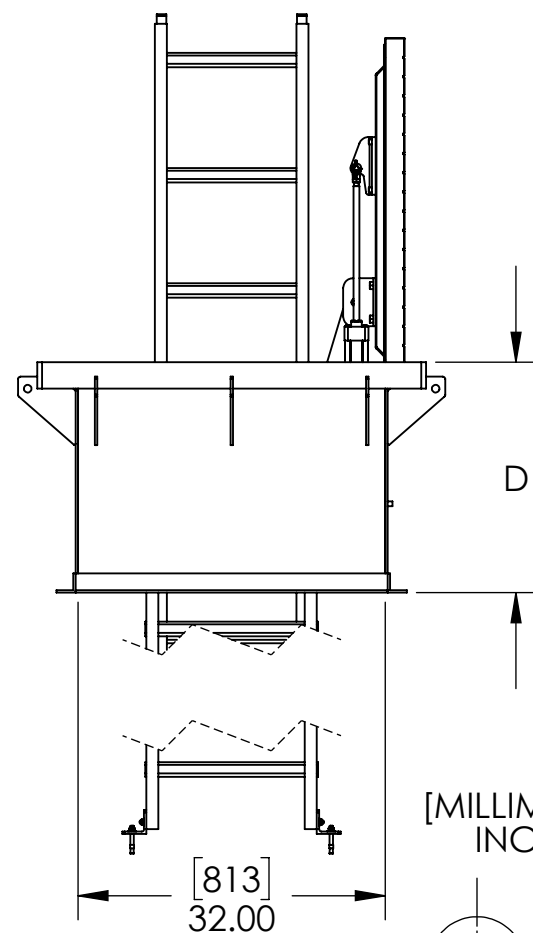

SIDE VIEW

STANDARD DEPTHS "D"

IN	MM	WT (LB)	WT (KG)
18	457	1349	612
24	610	1423	645
36	914	1576	715
48	1219	1731	785

OTHER DEPTHS AVAILABLE UPON REQUEST



APPROVALS	DATE
DRAWN DLL	01-13-25
CHECKED DLL	01-13-25
APPROVED CDM	01-13-25
SHEET 1 OF 2	
SCALE: 1:20	SIZE: B

USS, LLC
PHONE: (260) 693-1172 FAX: (260) 693-1178
WEB SITE: WWW.USSPECIALISTS.COM

USS36x60-32x56
VA(SD,HO,L)-Steel
3 VIEW, CUT, PLAN

THE INFORMATION ON THIS DRAWING IS PROPRIETARY AND IS NOT TO BE REVEALED TO THIRD PARTIES WITHOUT WRITTEN CONSENT OF A CORPORATE OFFICER OF USS, LLC.

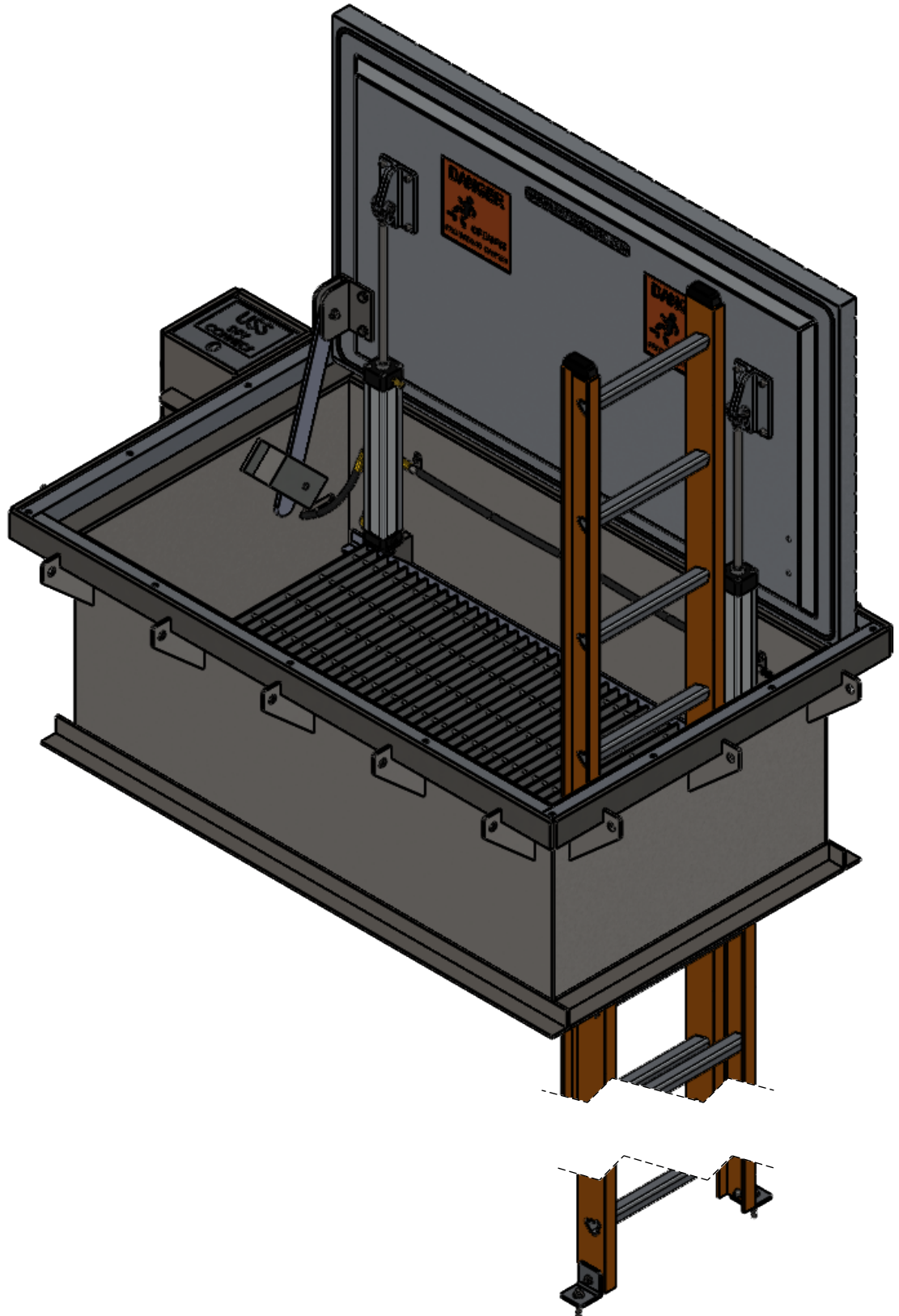

QUANTITY: _____

RELEASE FOR FABRICATION

NAME _____ SIGNATURE _____
 DATE _____ COMPANY _____

APPROVALS	DATE
DRAWN DLL	01-13-25
CHECKED DLL	01-13-25
APPROVED CDM	01-13-25
SHEET 2 OF 2	

USS, LLC
 PHONE: (260) 693-1172 FAX: (260) 693-1178
 WEB SITE: WWW.USSPECIALISTS.COM
USS36x60-32x56
VA(SD,HO)
SUBMITTAL

[MILLIMETERS]
INCHES

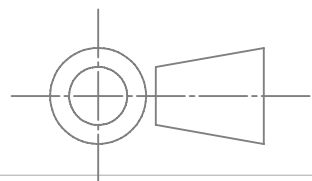

Utility Systems Specialists

SCALE: 1:13 SIZE: B

THE INFORMATION ON THIS DRAWING IS PROPRIETARY AND IS NOT TO BE REVEALED TO THIRD PARTIES WITHOUT WRITTEN CONSENT OF A CORPORATE OFFICER OF USS, LLC.